

What equipment is in a home electrical distribution box





What equipment is in a home electrical distribution box

How to Choose a House Distribution Box

Choosing the house distribution box that best fits your home is important for your safety and the efficiency of your electrical system. It facilitates the flow of electricity, guards appliances, and



What does a power distribution box do ?

In many electrical systems, especially those in areas with fluctuating power supplies or where sensitive electrical equipment is used, voltage regulation is of utmost



What is the Internal Structure of The Distribution Box

Learn about the internal structure of a distribution box, its components, functions, and key types. Understand its role in electrical systems



Distribution Box and Selection Guide

Distribution Box Selection Guide This guide provides information on how to select the appropriate Distribution Box for Electric project. If you have any

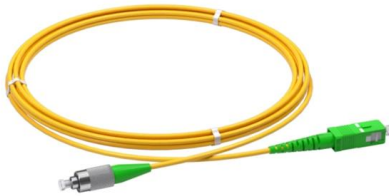

Distribution Box Guide: Types, Components & Solutions

Understand distribution boxes (DB boxes) in 5 minutes. Learn about types, components, functions, and uses. Find the perfect DB box for your needs.

Distribution Boxes Explained: Types, Functions, and

Inside, you will typically find switches, fuses, or circuit breakers, each helping to control and protect the flow of electricity. These components ensure



Power Distribution Boxes Explained Simply

Key components include circuit breakers, fuses, bus bars, and internal wiring for safety and organization. It ensures load balance, prevents



Mains Electric Box: What is it and what does it do?

The mains electric box is a square or rectangular box made from plastic or metal that is installed somewhere in our homes. The incoming live electricity feed enters the



Understanding Distribution Boxes:A Comprehensive Guide

Understanding its significance, this article covers what a distribution box is, how it functions, its structure, the various types available, and how it

Distribution Box: Types and Functions , Axis-Electricals

A distribution box ensures that electrical supply is distributed in the building, also known as a distribution board, panel board, breaker panel, or electric panel. It is



Distribution Boxes: Types and Functions

Learn what an electrical distribution box (DB/distribution board) is, its main components (MCB/RCCB/RCBO, SPD, busbar) and common types.



What Is an Electrical Distribution Box? A Complete Guide

It typically contains essential components such as circuit breakers, surge protectors, and grounding bus bars, ensuring safety and operational



A Definitive Guide To Distribution Boxes

The distribution box acts as the center of power distribution, distributing electricity to all connected devices. A distribution box, also known as a distribution board, panel board, breaker

Power Distribution Box Essentials: Functions, Types

+ Easy Maintenance: Easement in isolating specific circuits to be worked on for upgrades and repairs without turning off the entire electric system.



What Is a Distribution Box?

A distribution box is a device that, as the name suggests, is designed to distribute electrical power. It takes the electrical power from the main power



Distribution Box Guide: Types, Components & Solutions

It acts as a protective enclosure that houses several key components, such as circuit breakers, fuses, and bus bars. These components work together

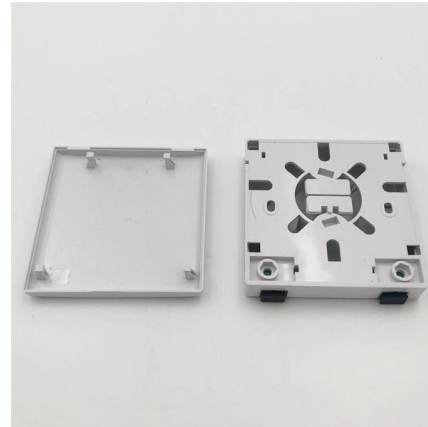

Understanding Distribution Boxes: A Comprehensive Guide

Learn what a distribution box is, its types, and how to choose the right one for your project. Includes clear examples and expert tips.

Power Distribution Boxes Explained Simply

Learn what a power distribution box is, how it works, key components, types, and why it's vital for safe and efficient electrical systems.

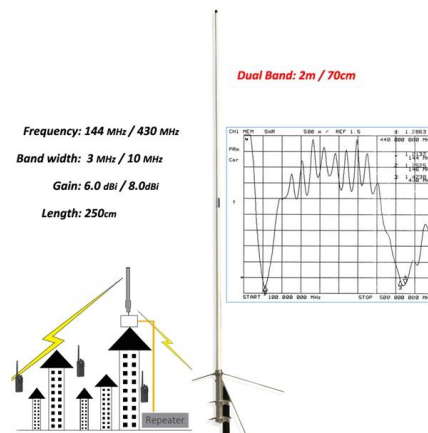

Distribution Boxes: Types and Functions

Inside a distribution box are components like circuit breakers, earth leakage units, doorbells, and timers. The building's electrical power enters



ITPro Today, Network Computing, IoT World Today combine

ITPro Today, Network Computing and IoT World Today have combined with TechTarget . The page you are looking for may no longer exist.

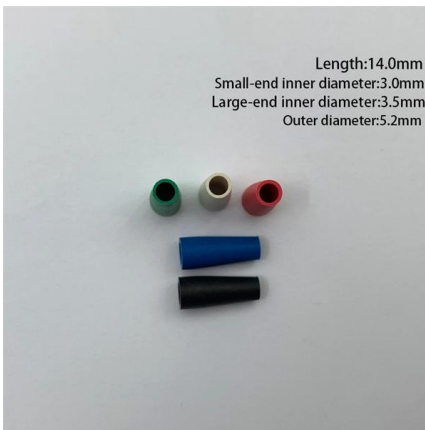
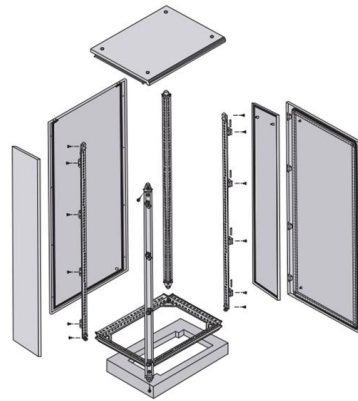

Distribution Boxes Explained: Types, Functions, and

Learn about distribution boxes, their types, functions, and safety features to ensure efficient and secure electrical power distribution in any building.

The Complete Guide to Distribution Box: Installation, Types & More

Home distribution boxes typically handle single-phase power supplies and contain 6 to 24 circuits. They include standard circuit breakers for lighting, outlets, and major appliances like water



The Ultimate Guide to Distribution Box Types

Discover the key types of distribution boxes with NUOMAK's comprehensive guide. Learn about Main Distribution Boards (MDB), Consumer Units, Transfer

What is the Function of a Distribution Box



in Electrical Systems

The distribution box plays a crucial function in the distribution box of electrical systems. It helps electricity move safely to different circuits, ensuring that power is utilized efficiently. This box protects



Contact Us

For datasheets, pricing, or custom high-speed optical interconnect solutions, please visit:
<https://www.syropy.com.pl>