

# **Waterproofing of Outdoor Sheet Metal Distribution Boxes on Construction Sites**

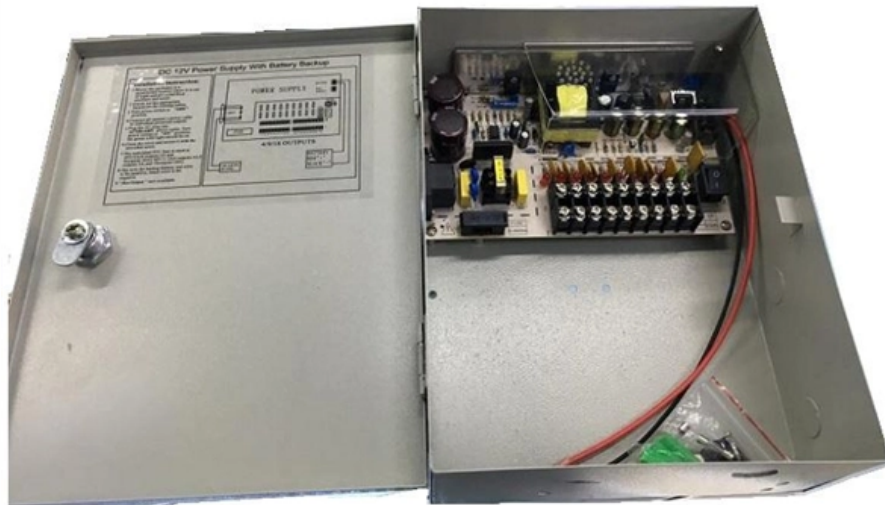



## Overview

---

Waterproof distribution box manufacturers tell you that the way to waterproof an outdoor distribution box is to first choose a distribution box made of waterproof material, seal the cable entry points, apply silicone sealant, install a weatherproof cover, use. However, the outdoor environment is complex and changeable, and extreme weather, sandstorms and other phenomena often occur, which requires metal distribution boxes to have good waterproof and dustproof performance to ensure the stable operation of the power system. Key design points include high-quality materials like ABS plastic, aluminum, and stainless steel that resist corrosion and UV. Workers need power for tools, lighting, pumps, welding equipment, lifting devices, testing instruments, and temporary offices. It's imperative to design sheet metal fabricated electrical enclosures for the right National Electrical Manufacturer Association (NEMA) protection rating to ensure that electrical components aren't exposed to the elements. This sophisticated enclosure system serves as the primary barrier between sensitive electrical equipment and.



## Waterproofing of Outdoor Sheet Metal Distribution Boxes on Constr

---



### Premium Waterproof DB Box Solutions

Discover superior waterproof db box systems offering unmatched protection for electrical distribution equipment. Our advanced waterproof db box solutions feature multi-layer sealing technology,

### Best Practices for Weatherproofing Sheet Metal

In our experience providing sheet metal fabrication services for NEMA enclosures, we've identified four helpful weatherproofing tips.

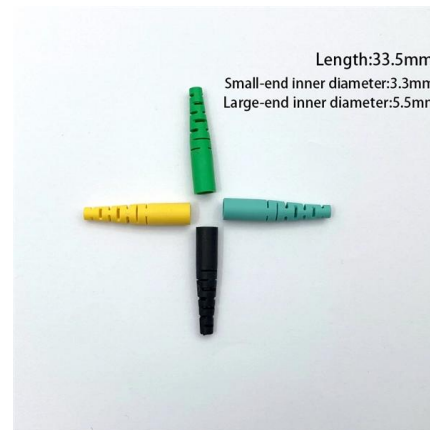

### Waterproof Distribution Box , IP65 & IP66 Rated

ZCEBOX manufactures IP65 & IP66 waterproof distribution boxes for outdoor and industrial applications. Built with durable materials, CE & ROHS certified. Contact

### Temporary Power Distribution Box for Construction Sites and Outdoor

Learn how CEE socket distribution boxes, IP-rated outdoor electrical enclosures, emergency stop buttons, elevated stands, and structured wiring reduce water ingress, cable



### Outdoor Power Distribution Boxes: The Backbone of

Explore J&H Group's full range of custom cable solutions and sheet metal fabrication for tailored outdoor power projects. Choosing the Right

### The Role and Application of Distribution Box Waterproof Enclosures

Outdoor Application: A municipal project required outdoor distribution boxes that are waterproof, dustproof, and resistant to temperature changes. By customizing weather-resistant waterproof



### Weatherproof Outdoor Distribution Boxes: Key Design Insights

Learn the key design points for weatherproof outdoor distribution boxes to ensure durability, safety, and compliance in challenging environments !





### How To Waterproof Outdoor Concrete Planter Boxes

Seamless waterproofing is the industry standard for waterproofing outdoor planters. Seamless waterproofing is fluid-applied waterproofing, which



### Construction Waterproofing Methods , SafetyCulture

Bituminous Membrane Waterproofing Considered one of the most reliable types of waterproofing in construction, these factory-made bitumen



### Low voltage distribution box: weatherability standard and protection

Low voltage distribution box outdoor use requires IP65 or NEMA 4X ratings, corrosion-resistant materials, and proper sealing for lasting weather protection.

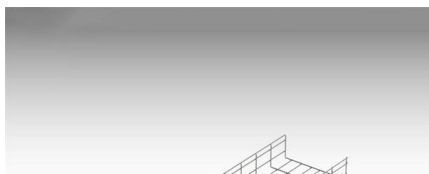

Grid Cable for marine and offshore applications

### Waterproof distribution box manufacturer tells you, How do you

Waterproofing of outdoor electrical boxes is critical to protecting electrical components from moisture and ensuring safety. Here is a step-by-step guide on how to waterproof an outdoor



## Stop Water Intrusion: Waterproofing a Metal Building

Properly sealing and waterproofing your metal building is essential to prevent water intrusion. Water infiltration in a prefabricated metal building, especially tube-style

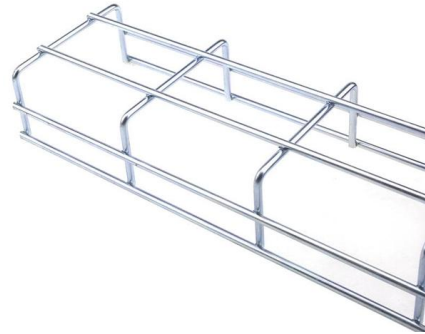

## Enhancing Protection and Reliability: The Power of Waterproof

In environments where exposure to moisture, dust, or extreme temperatures is a concern, the incorporation of waterproofing features becomes paramount. A waterproof distribution

## Enhancing Protection and Reliability: The Power of Waterproof

A waterproof distribution box is constructed with materials and designs that effectively prevent the ingress of water and other contaminants. This level of protection is particularly crucial in

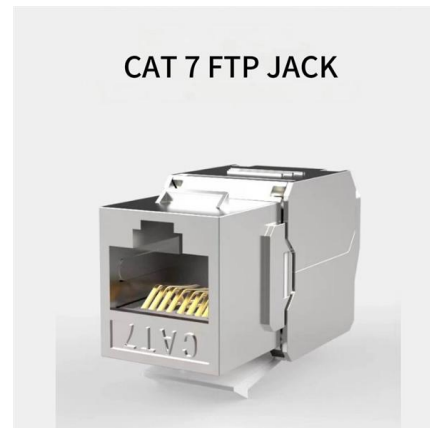

## how to install a waterproof electrical box

With the continuous development of urban construction, the demand for power facilities is also increasing. As an important part of the power system,



## Circuit Breaker Distribution Box Electrical,



## Outdoor

This distribution box is Made of high quality plastic material, durable and sturdy. This distribution box is designed for 5/8/12/15/18/24 ways circuit breaker. you can



## Waterproofing a Metal Building: What You Need to Know

Properly waterproofing a metal building will stop moisture infiltration that can damage finished materials, corrode metal components, and diminish the



## What is a waterproof outdoor distribution box

A waterproof outdoor distribution box shields electrical connections from water, dust, and weather, ensuring safe and reliable outdoor power distribution.



## Keep It Dry: How to Waterproof Outdoor Electrical Boxes

Learn how to waterproof outdoor electrical boxes with practical tips on enclosure selection, sealing, installation, and maintenance.



## 6 Steps to Waterproofing Construction on A Building Site

Learn the 6 essential steps to waterproofing construction sites to prevent long-term damage. A practical guide from the experts at Michaels Sheet Metal.

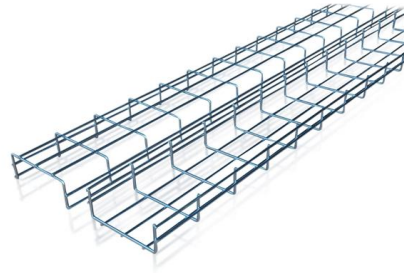

### Outdoor Waterproof Enclosure Box - TSM Series Plastic

TSM Series Outdoor Waterproof Enclosure Box are designed to protect electrical components in different environments and industry.

### An Ultimate Guide for Metal Distribution Boxes

This article guides readers to know advantages of metal distribution box compared with plastic ones and safety measures are also included.



### What special treatments have been done on outdoor

In short, the box has done a lot of special treatment in terms of waterproofing and dustproofing to ensure that it can operate stably in complex



### Waterproof Distribution Box (IP65-IP68)

IP65 waterproof distribution box for outdoor installs. Plastic ABS/PC, DIN-rail ready, clean wiring, customization available. Manufacturer support & accessories.



### 1.An Ultimate Guide for Metal Distribution Boxes

1) Metal Distribution Boxes Constructed from steel, aluminum, or cast iron, metal distribution boxes are highly durable and resistant to mechanical damage. Ideal

## Contact Us

---

For datasheets, pricing, or custom high-speed optical interconnect solutions, please visit:  
<https://www.syropy.com.pl>