

The function of an optical time domain reflectometer





The function of an optical time domain reflectometer



ST3300 OTDT Optical Time Domain Reflectometer

As fibre optics plays more and more important role in modern telecommunication and CATV networks, the requirements to the construction, test and maintenance of fibre optics links also become more

What Is OTDR: Optical Time Domain Reflectometer Explained

An OTDR, or optical time domain reflectometer, is a fiber optic testing instrument that sends pulses of light down a fiber cable and analyzes the light that bounces back.



How to Repair Fiber Optic Cable: Top 5 Easy Steps (2024)

An Optical Time-Domain Reflectometer (OTDR) is a vital tool for testing fiber optic cables. It sends a series of light pulses down the fiber and

Amazon : Otdr

Discover OTDR testers that combine versatility, portability, and advanced measurement capabilities. Streamline your fiber optic network testing and



Optical Time-domain Reflectometers - OTDR, operation

Optical time-domain reflectometers inspect fiber-optic links, measuring losses and reflections from faulty connections or splices.



Mini Multimode Optical Time-Domain Reflectometer OTDR

Buy high-end and discount mini multimode optical time-domain reflectometer OTDR from our factory. As one of the leading manufacturers and suppliers in China, we

02

High Quality Material

||

High hardness to resist external impact, Good Shaping Performance, Good Look and Anti-rust



Optical Time Domain Reflectometers

An Optical Time Domain Reflectometer (OTDR) is a precision tool used to detect faults and measure loss along fiber optic links by analyzing backscattered light





ST3200 OTDR Optical Time Domain Reflectometer

ST3200 OTDR (Optical Time Domain Reflectometer) is an intelligent optical fiber communication tester. This tester is easy to use and portable, which has a 3.5-inch color LCD touching screen. It also



Fiber Optic Troubleshooting: Expert Guide for Common

Several tools and test equipment are used in fiber optic troubleshooting, including: Optical time-domain reflectometer (OTDR): This

Distributed optical fiber sensors: what is known and what

In their most common implementation, known as Optical Time-Domain Reflectometry (OTDR), an intense light pulse is launched into the optical fiber,



WHITE PAPER: Understanding Optical Time Domain Reflectometers

Since the 1980s, OTDRs have been used to characterize fiber links, identify optical events, measure event loss, location, reflectance and identify events that can impact the fiber optic network service



Phase correction based measurement enhancement for μ -OTDR

Distributed acoustic sensing (DAS) based on phase-sensitive optical time-domain reflectometry (μ -OTDR) has emerged as a transformative technology in distributed fiber-optic



Optical Time-Domain Reflectometers (OTDRs)

An optical time domain reflectometer, or OTDR, is a device that tests the integrity of a fiber optic cable, as well as the loss and reflectance of fiber splices, by measuring its various characteristics using

Optical frequency domain reflectometry sensing for damage detection

With the development of optical frequency-domain reflectometry (OFDR)-based distributed strain sensing technology and static influence line (IL) measurement concept, the special

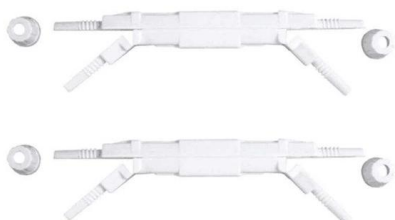
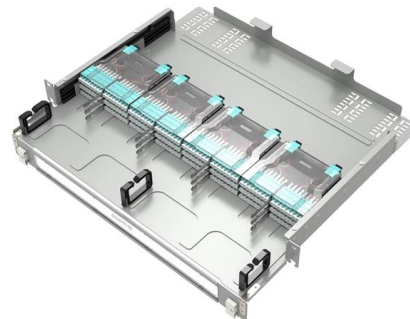

(PDF) Dynamic optical frequency domain reflectometry

Abstract and Figures We describe a dynamic Optical Frequency Domain Reflectometry (OFDR) system which enables real time, long range,



Optical fibre sensors for geohazard monitoring - A review

Optical fibre sensors have emerged as promising tools due to their inherent advantages. Various types of optical fibre sensors used in geohazard monitoring, categorized as distributed



Navigating the Competitive Landscape of the Portable Optical Time

The competitive landscape of the Portable Optical Time Domain Reflectometer (OTDR) market is characterized by rapid technological advancements and evolving customer requirements.

Europacable Technical newsletter Optical time domain reflectometer

In practice, a launch coil is inserted between the reflectometer and the network to be measured to avoid having a dead zone at the reflectometer output and to allow the characterisation of the first connector



Anritsu MW9076B Display Optical Time Domain Reflectometer 6 Hour

Key attributes place of origin Japan brand name Anritsu Price Contact us Product name Display Optical Time Domain Reflectometer 6 Hour Battery Life Function Normally Condition Contact us Guarantee 1



OTDR - Optical Time Domain Reflectometer

The primary function of an OTDR is to detect and measure back-scattered or reflected light caused by imperfections, splices, bends, and faults

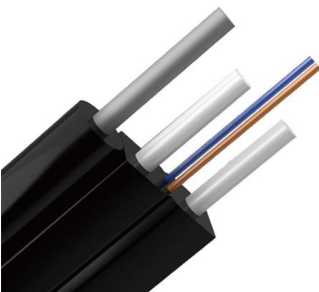
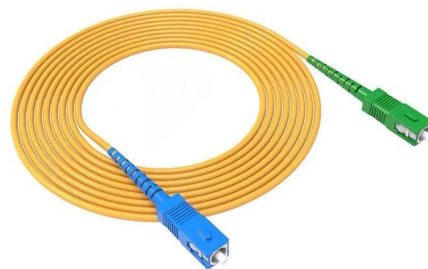

TMO300

The TMO300 from WolonFiber is a Optical Time Domain Reflectometer (OTDR) with Event Dead Zone 1 m, Attenuation Dead Zone 6 m, Optical Wavelength 1310 to 1550 nm, Dynamic Range 30 to 32 dB,

What is an Optical Time-Domain Reflectometer (OTDR)

The Optical Time-Domain Reflectometer (OTDR) is a cornerstone tool in fiber optic network management, offering critical insight into fiber





Time Domain Reflectometry

Optical time domain reflectometry is used to measure the transmission characteristics of optical fibers by measuring the Rayleigh backward scattered light and Fresnel reflected light generated when an

What is an Optical Time Domain Reflectometer (OTDR)?

An Optical Time Domain Reflectometer (OTDR) is an instrument used for detecting and analyzing scattered or back-reflected light within optical fibers, pinpointing impurities and imperfections.

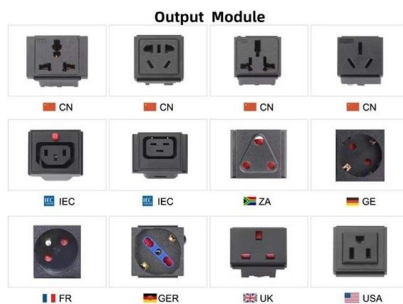

Why Choose Us

- 20 Years of OEM/ODM**
20 Years factory manufacturing experience.
- Professional R & D team**
10 years experience in mold/electronic engineer.
- Fully Certified**
Our are certified CE, FCC, RoHS, ISO9001, ISO13168 etc.
- Timely Delivery**
22 production lines, 500+ employees, timely delivery guaranteed.
- Quality Assurance**
Professional QC team with full process inspection.
- After-sales service**
After-Sales Service for Customer Satisfaction.

The FOA Reference For Fiber Optics

The Optical Time Domain Reflectometer (OTDR) is useful for testing the integrity of fiber optic cables. It can verify splice loss, measure length and find faults. The

Accurate estimation of modulation amplitude in Brillouin optical

In Brillouin optical correlation-domain reflectometry (BOCDR), spatial resolution relies on the modulation amplitude of the light. We propose a Rayleigh-based method that utilizes the spectral

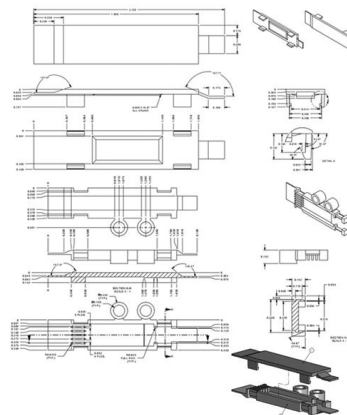



Various specifications optional



OTDR Multi-function 1550nm Touch Screen Optical Time Domain

The OTDR Multi-Function 1550nm Touch Screen Optical Time Domain Reflectometer is an essential tool for professionals in the fiber optic industry. Designed for precision, this device offers high

Contact Us

For datasheets, pricing, or custom high-speed optical interconnect solutions, please visit:
<https://www.syropy.com.pl>