

# Relay protection device handle

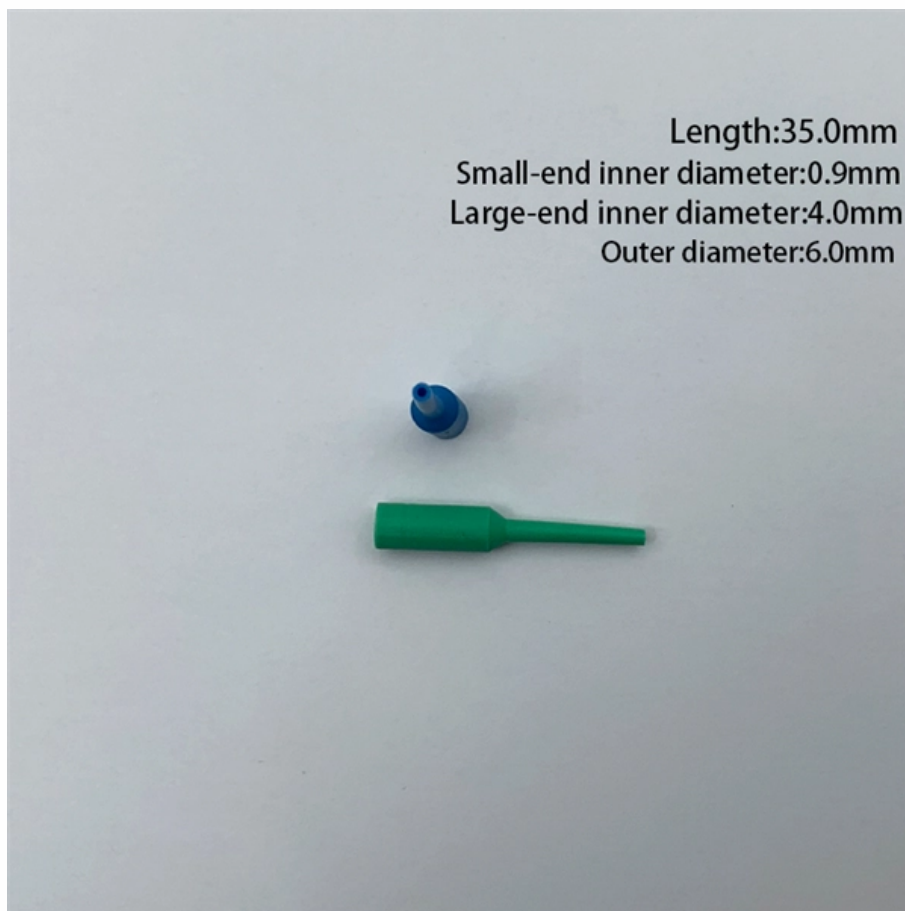



## Relay protection device handle

---



### Basic Types of Protection Relays and Their Operation

Protective relays are the building blocks used to develop protection systems. Digital relays held an enormous advantage over any of their predecessors with the new ability to add

### Types of Electrical Protection Relays or Protective Relays

A protective relay is an automatic device that detects



### Protective Relaying

Typical Relay and Circuit Breaker Connections  
Protective relays using electrical quantities are connected to the power system through current

### Protective Relay: Working, Types, and Applications

Learn about protective relays, their working principle, types, and applications in power systems. Discover how relays protect transformers,



### Safety Products

Our innovative safety products and solutions improve the functional operation of your machinery while helping to increase personnel safety, efficiency and productivity.



### Basic protection relay knowledge

A fast and selective arc fault mitigation for air-insulated LV & MV switchgear and Relion protection and control relays and sensor technology protect staff and plant facilities for many years.

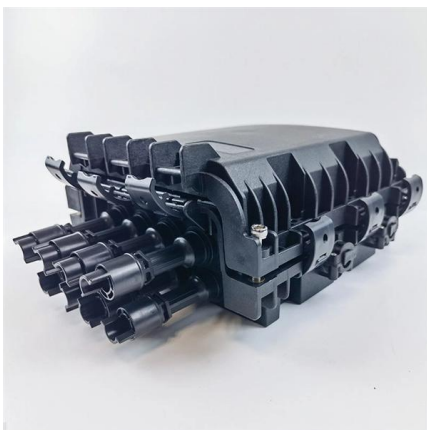

### Voltage Protection Relay: Working Principle and Functions

A voltage protection relay is an essential device to keep electrical systems running efficiently and safely. These devices are designed to suit many unique situations.



## The Basics of Control Relays , Relay Control Systems

The Basics of Control Relays Relays are magnetic electromechanical devices with two primary purposes: to isolate different circuit voltages, and to form larger

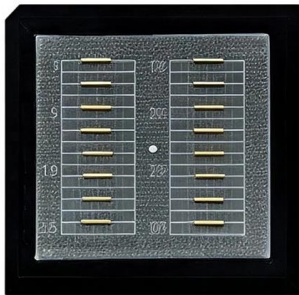

### Protection Relay:Types, wiring diagram and working principle.

Protection relay is an electromechanical monitoring safety device which senses fault and provide trip signal to the breaker as per set value in LT and HT panel.

### Protection Relay Types and Testing Procedures

Introduction In modern electrical systems, protection relays are critical for ensuring safe and efficient operations. These devices safeguard assets



### Protection Relay : Circuit, Working, Types, Codes & Its

Thus, this is an overview of the protective relay or protection relay, working, circuit, types, functions, codes, characteristics, advantages,

### Electromechanical Relay



Electromechanical relay is a reliable, robust and universal switching device for electrically isolating control signals from high power loads.



### Protective Relay : Working, Types, Circuit & Its

There are different types of relays available and each type is used based on the requirement. So this article discusses an overview of a protective relay or



### Types of Protective Relays

A protective relay is a device that detects the fault and initiates the operation of the circuit breaker to isolate the defective element from the rest of the system.



### What is Protection Relay?

A protection relay is a crucial component of electrical systems that safeguard infrastructure, employees, and equipment from electric problems and





### Auxiliary and Lockout (86) Relays

An important type of "accessory" relay, especially for legacy electromechanical protective relays, is the so-called auxiliary or lockout relay, designated by the

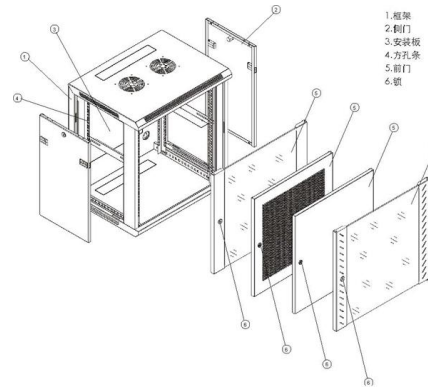

### Power System Protective Relays: Principles & Practices

Protective relays and devices have been developed over 100 years ago to provide "lastline"of defense for the electrical systems. They are intended to quickly identify a fault and isolate it so the balance of



### The basics of power system protective relaying , EEP

Protective Relaying The IEEE defines protective relays as: "Relays whose function is to detect defective lines or apparatus or other power system

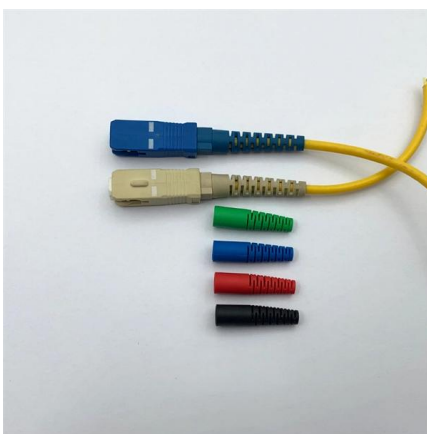

### Understanding Protection Relays in Electrical Power Systems

This device plays an essential role in monitoring electrical systems, detecting faults, and initiating actions to prevent further damage to equipment and ensure the safety of personnel. In this article, we

### Protection and Control Device Numbers and Functions



The protection and control devices in electrical equipment can be referred to by numbers, with appropriate suffix letters when necessary, according to the functions they perform.



### **Understanding Protective Relays in Electrical Power Systems**

Introduction to Protective Relays Protective relays are essential devices used in electrical power systems to detect faults and abnormal conditions, initiating corrective actions to prevent equipment

### **Understanding Protective Relays in Electrical Power Systems -**

Introduction to Protective Relays Protective relays are essential devices used in electrical power systems to detect faults and abnormal conditions, initiating corrective actions to prevent equipment



### **Protection relays**

Protection relays Numerical relays are based on the use of microprocessors. The first numerical relays were released in 1985. A big difference between conventional



## Protective relay

The fault can be located upstream or downstream of the relay's location, allowing appropriate protective devices to be operated inside or outside of the zone of



## High Voltage Relays

HV Relays: Hermetically sealed for harsh environments High voltage relays are electromechanical devices whose purpose is to switch to high voltage signals (> 1kV) and high frequency applications.

## Practical handbook for relay protection engineers , EEP

This handbook covers the code of practice in protection circuitry including standard lead and device numbers, mode of connections at terminal



## Contact Us

---

For datasheets, pricing, or custom high-speed optical interconnect solutions, please visit:  
<https://www.syropy.com.pl>