

Optical modules and RF chips





Optical modules and RF chips



Electronic Chip Package and Co-Packaged Optics

Advanced packaging technologies, such as 3D chiplets hetero-integration and co-packaged optics (CPO), have become crucial for further

Do optical modules require RF chips? , Weyland

Optical modules are crucial components in modern communication networks, responsible for converting electrical signals into optical signals. Radio Frequency (RF) chips, in contrast, are

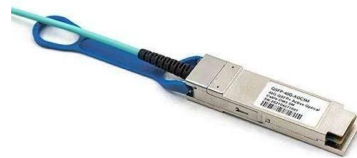

Optical Chips: Types, Applications, and Future Trends

This comprehensive guide will explore optical chips, their types, applications, their impact on optical module performance, and the exciting future

400G Silicon Photonics Integrated Circuit Transceiver Chipsets for

To test compatibility with 400G-FR4 MSA, transmit and receive optical sub-assemblies (TOSA and ROSA) were assembled by wire bonding the Analog Photonics Tx and Rx PICs directly to

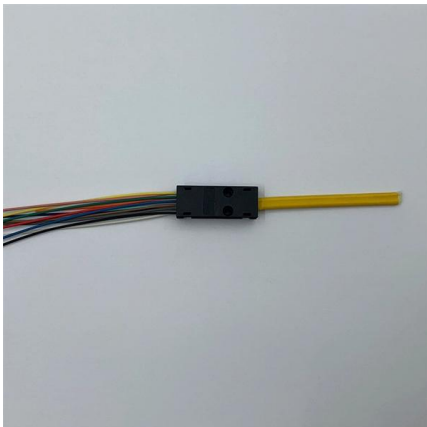
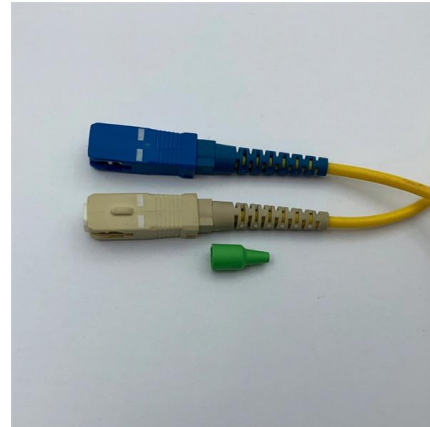

RF Over Fiber Modules

RF-over-fiber modules transport RF signals over optical links to reduce coax loss and extend distance, using linearized transmit/receive optical chains. They are specified by RF bandwidth, dynamic range,

Broadcom Sian3 and Sian2M: 200G/lane optical

Analyzing Broadcom's Sian3 and Sian2M 200G/lane DSP technologies. Sian3 (3nm/SMF) and Sian2M (5nm/MMF) support 800G and 1.6T

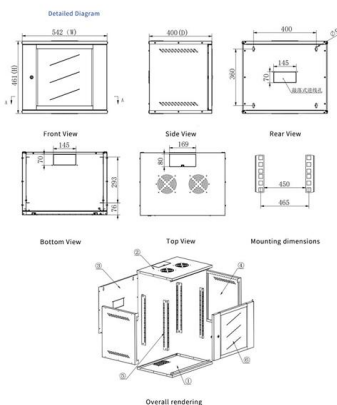

RF over Fiber & Optical Delay Lines System Solutions

RF over Fiber and Optical Delay Line system solutions for superior signal reach in telecom, 5G, broadcast, EW, & aviation industries.

Miniaturized and high-performance RF



packages with ultra-thin glass

Glass packaging in 2D and 3D is emerging as an ideal solution for high-performance and ultraminiaturized RF front-end modules with simultaneous reduction in both X-Y and Z directions.



Programmable optical processor chips: toward photonic

Integrated optical signal processors have been identified as a powerful engine for optical processing of microwave signals. They enable wideband and stable signal

Google's High-Speed Interconnect Architecture to Push

Google's next-generation TPU, Ironwood, integrates a 3D Torus network topology with the Apollo optical circuit switch (OCS) all-optical network,



Programmable optical chips for integrated microwave photonics RF

Programmable optical chips are a key technology for integrated microwave photonics. They enable flexible and stable signal processing operations on miniaturized chips with ultimate



Which has better development prospects: optical modules or RF chips

Both optical modules and RF chips represent major directions for the communication industry over the next decade. At present, driven by AI and computing infrastructure expansion, high



Exploring Dual-Mode RF/Optical DSN Transceiver Chips: The Future

Explore the advancements in dual-mode RF/optical transceiver technology, which seamlessly integrates radio frequency and optical communication systems to enhance data transmission capabilities. Learn



Comprehensive Overview of CPO (Co-Packaged Optics)

It integrates the CPO optical module with the ASIC (Application-Specific Integrated Circuit) chip in the switch, thereby shortening interconnect



RF module

RF modules typically incorporate a printed circuit board, transmit or receive circuit, antenna, and serial interface for communication to the host processor. Most



Where co-packaged optics (CPO) technology stands in

Co-packaged optics (CPO) technology, a key enabler for next-generation data center architectures, promises unprecedented bandwidth density



RF over Fiber

RF over Fiber (RFoF) is the transmission of analog radio frequency signals over optical fiber. It involves the transmission of RF signals directly through light, enabling high-fidelity, long-distance signal

Do optical modules require RF chips? , Weyland

Conclusion Optical modules do not inherently require RF chips, as their primary function is fiber-optic data transmission. RF chips are essential for wireless access, mobility, and over-the-air



Modulators

The TFLN modulators extend the optical wavelength from 450 nm to 4500 nm. The devices are applied for high-speed modulation, quantum computing and for

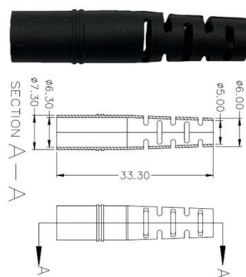



Optical module

Optical modules can either plug into a front panel socket or an on-board socket. Sometimes the optical module is replaced by an electrical interface module that implements either an active or passive



A Comprehensive Guide to Optical Chips

Optical chips, typically referred to as photonic chips, use light waves (electromagnetic waves) as carriers for information transmission or data processing. These chips rely on integrated

Optical, RF, & Microelectronics Solutions , Integrated

Focused on high technology OEMs who require innovative optical, RF and microelectronic solutions, Sanmina provides integrated design and manufacturing



AI Data Centers Ignite a Laser Shortage Wave; Nvidia's

Nvidia's strategic monopoly on EMLs Beyond VCSELs used in short-reach links, mid- to long-reach optical modules mainly depend on two laser types:



Programmable optical processor chips: toward photonic

Here, the recent progress of integrated optical signal processors for implementing such RF filters is reviewed.



Contact Us

For datasheets, pricing, or custom high-speed optical interconnect solutions, please visit:
<https://www.syropy.com.pl>