

# **Old-style distribution box air switch**

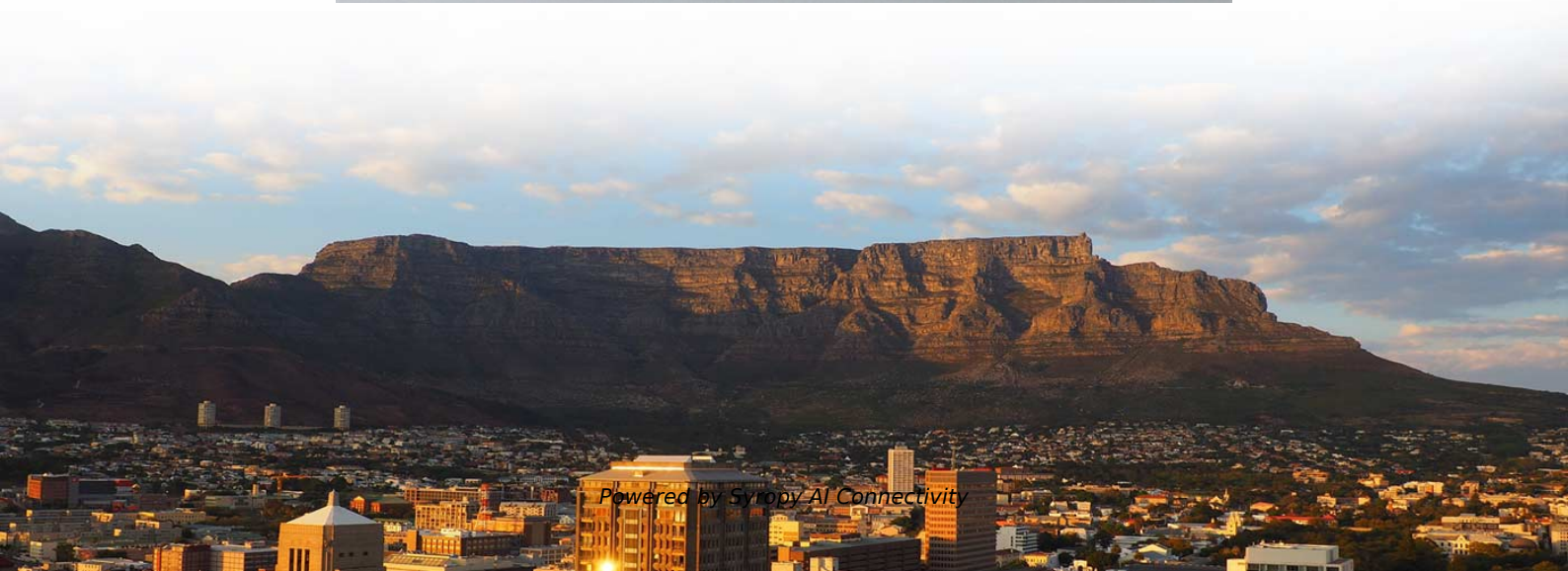



## Old-style distribution box air switch

---



### **Air Conditioning Distribution Box: Essential Guide to Function, Types**

The Air Conditioning Distribution Box is a critical electrical component that centralizes power distribution for cooling systems while providing protection and ease of maintenance. This

### **AMT Handbook**

Aircraft magneto-ignition systems can be classified as either high-tension or low-tension. The low-tension magneto system, covered in a later section of this chapter, generates a low-voltage that is



### **Premium High-Performance Switches for Classic Car Systems**

Enhance your classic car or truck's air conditioning system with reliable A/C switches from Classic Performance Products (CPP). Our selection of trinary and binary switches, from top brands like



### **Adding A Garbage Disposal Air Switch: A Simple Guide**

Last week, I was frustrated. My old garbage disposal was noisy and smelled, and I knew there had to be a better way. I'd heard about adding an air switch, but the instructions online were confusing. This



### Air Operated Switches

New style parallel air motor with micro switch:  
Here is a second style of air motor that is parallel to the track and can be ordered with a (real) waterproof microswitch inside.

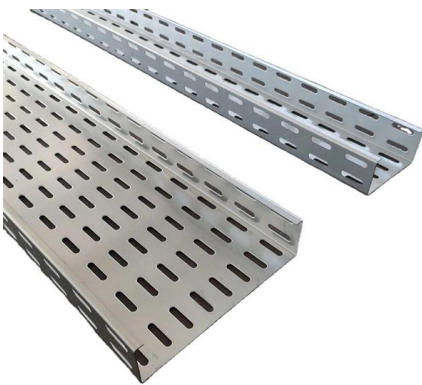

### Nagaland News, India News, Northeast News

The Morung Express brings the Latest News, Top Breaking headlines on Politics and Current Affairs in Nagaland India and around the World, Naglaand News, Naga



### Air Switch Kits

Presair Air Switch Kits use a pulse of air to control power on and off, providing safe, contact-free switching. The electric-to-pneumatic converter box is compatible with

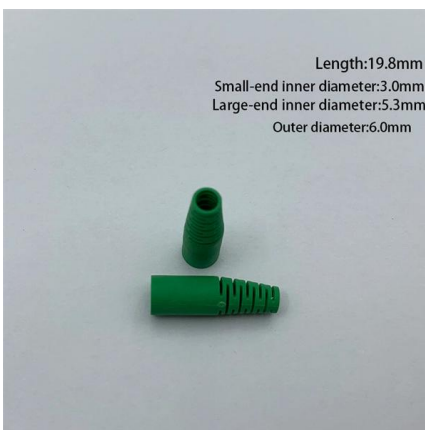



## **Air Excellent distribution box DB824 125-200 24**

Detailed information The Air Excellent distribution box DB824 is a versatile and efficient solution, complete with a stepped adaptor, 24 internal air restrictor rings,



## **Vintage-Style Light Switches and Outlets**

Vintage-Style Light Switches and Outlets In the late 19th and early 20th centuries, the rise of electricity in homes and businesses led to the

## **9 Old Breaker Boxes You Should Replace**

These old breaker boxes are easily recognizable as they don't have switches but buttons you need to push when switching them off. They were



## **How does an air switch work? A simple guide , Herga**

Find out how air switches work and where they are used. They are especially safe for environments with water or moisture.



### Air Break Switch

The air break switches install in outdoor and mainly use for switching and isolation. The air break switch is mostly installed in the distribution network as a switching



### Air Gaps & Air Switches - Westbrass

Sink Top Waste Disposal Air Switch and Single Outlet Control Box, Flush Button \$ 146 Select options



### What Is Air Switch and How It Works

Air switch is a very common in our low voltage power grid, but also a very important electrical appliance. It combines control and multiple protections.



### Airswitch Switching and isolating equipment for metal-enclosed

Fields of application The rotary and hinged isolators and switch-disconnectors are used in secondary distribution substations as feeder switching and/or isolating apparatus, for transformer power supply



## Air Break Switch

In this article, we will discuss a type of switchgear called an air break switch, its types, and applications in the electrical industry. Let us start with the

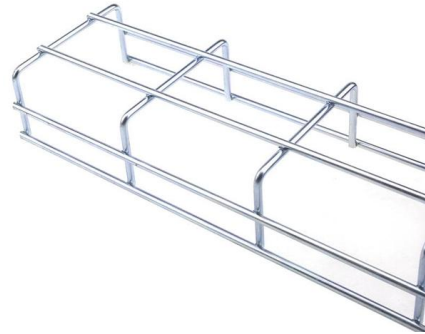

### Wiring requirements and specifications for air switches in distribution

Singi Electrica is China manufacturer & supplier who mainly produces miniature circuit breaker, mccb, distribution box, SPD, junction box with 25 years of experience.

### ED distribution enclosed air switch catalog

Eaton's Cooper Power™ series Type ED switch is a distribution enclosed single-pole air switch rated at 7.8 kV, 75 kV BIL, 400 and 600 A continuous current. The Type ED porcelain-housed disconnect



### How to Install a Garbage Disposal Air Switch

Pneumatic Air Switches: These are the most common types, using air pressure to control the switch. Electronic Air Switches: Instead of air, these use electronic signals to activate the



## Air Switches Selection Guide: Types, Features,

Air switches are typically used in applications where water is present but needs to be kept separate from electronic components. As the switch is activated by air

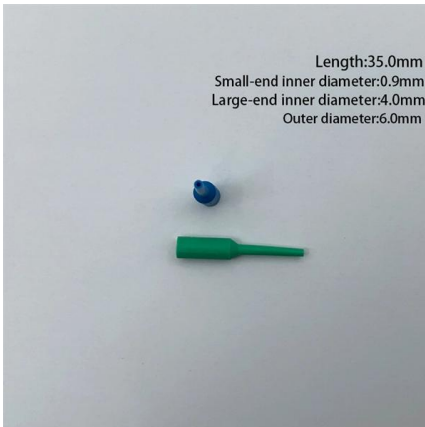
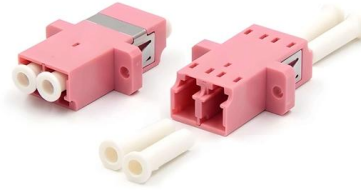

### Air Excellent distribution box DB206H125 6 connections

Detailed information The Air Excellent distribution box DB206H125 is a versatile and efficient solution, complete with a horizontal adaptor, 6 internal air restrictor rings, and 3 covers for unused

Hier sollte eine Beschreibung angezeigt werden, diese Seite lässt dies jedoch nicht zu.



### Air Flux switch boxes , Components for VRF systems

This range of 6 switch boxes AF-SB is compact and easy to install with only 195 mm for the smallest model, for all others only 250 mm installation height. Up to 8



## Contact Us

---

For datasheets, pricing, or custom high-speed optical interconnect solutions, please visit:

<https://www.syropy.com.pl>