

Noise in single-mode fiber





Overview

Modal interference can occur in single-mode fiber systems causing signal degradation and potentially lower signal or carrier to noise figures. Modal interference and modal noise can occur when field-installable connectors containing short fiber stubs, such as the Corning Cable Systems UniCam[®] and FuseLite[®], are used in single-mode systems. Exploring the use of single-mode fibers (SMFs) in high precision Doppler spectrometers has become increasingly attractive since the advent of diffraction-limited adaptive optics systems on large-aperture telescopes.



Noise in single-mode fiber



Single Mode Fibers

Coupling light into a single-mode fiber inevitably requires considerably tighter tolerances than those required by coupling light into the larger cores of a multimode fiber.

"MODAL NOISE" IN SINGLE-MODE FIBERS: A CAUTIONARY

Importantly, classical mode interference and speckle issues associated with multi-mode fibers, also known as "modal noise," are mitigated when using SMFs, which also provide perfect



The FOA Reference For Fiber Optics

Typical noise floors on fiber optic instruments using Si detectors is -70 to -90 dBm, or about 1 to 100 picowatts. Germanium detectors are sensitive to light in the 800 to

Modal Interference and Modal Noise in Single-mode Connectors

Modal interference and modal noise can occur when field-installable connectors containing short fiber stubs, such as the Corning Cable Systems UniCam£ and FuseLite£, are used in single-mode



VIAVI Reference Guide to Fiber Optic Testing Vol

Types of Fiber 6

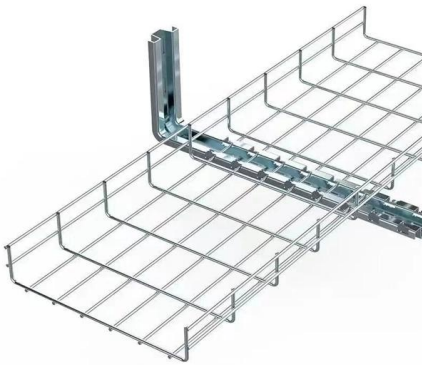

Media converters , Products , HMS Networks

Easily connect Ethernet to fiber cabling for faster data transmission, noise immunity, and extended range with our industrial media converters.

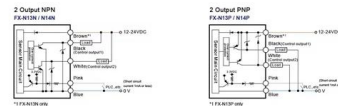

'Modal-noise' in single-mode fibers: A cautionary note for high

Importantly, classical mode interference and speckle issues associated with multi-mode fibers, also known as 'modal noise', are mitigated when using SMFs, which also provide perfect





Fiber testers : Equipment and tools , Fluke Networks

This single-mode and multimode MPO fiber testing kit eliminates the complexity of polarity issues, and it makes cassettes easier to test in the field. It's 90 percent



Fiber Optic Cable Distance: A Comprehensive Guide

Single-mode fiber optic cables are more suitable for long-distance, high-speed transmission than multimode fiber optics. For most applications, the

WuT data sheet: Universal FO-Interface 20mA

Reliably transmit TTY over very long distances
The model 41215 Interface features a selectable active or passive 20mA interface which the converter changes into a universal optical interface for single



Spark-X 1280 nm Fiber-Based Femtosecond Laser System

Overview The Spark-X 1280 nm Fiber-Based Femtosecond Laser System is an engineered ultrafast light source optimized for semiconductor failure analysis, nonlinear optical microscopy, and time-resolved



Sub-200 fs, 344 MHz mode-locked Tm-doped fiber laser.

To the best of the knowledge, the achieved repetition rate represents the highest value of fundamentally NPE mode-locked fiber lasers at $\sim 2\mu\text{m}$, while the average output power is also higher than the



#fiberlaser #thuliumlaser #photonics #industriallaser #

Built around singlemode $2\mu\text{m}$ fiber laser technology with FBG wavelength stabilization, this platform combines high beam quality, low acoustic noise, and long-term operational stability for

940 nm laser diode from 200 mW up to 200 W - fiber

These single mode and multi mode fiber-coupled 940 nm laser diodes are offered as stock items or associated with a CW or pulsed Turn-Key Laser Diode Driver.



Polarization noise in single mode fibres and its reduction by

The polarization noise, originating from the combination of single mode fibres and diffraction gratings, is investigated experimentally. A drastic deterioration of the signal/noise ratio is observed, which is





Modal Interference in Single Mode Optical Fiber Systems

Modal interference can occur in single-mode fiber systems causing signal degradation and potentially lower signal or carrier to noise figures. Modal interference results from the recombination of higher



Modal Interference and Modal Noise in Single-mode Connectors

Modal interference and modal noise can occur when field-installable connectors containing short fiber stubs, such as the Corning Cable Systems UniCam£ and FuseLite£, are used in single-mode systems.

Modal noise in single-mode fibers

So-called single-mode fibers are generally bimodal in that they can propagate two modes with orthogonal polarizations. If both transverse offset and angular misalignment are present in a single



Single-longitudinal-mode operation of a grating-based fiber-ring laser

A fiber Bragg grating-(FBG-) based fiber-ring laser that utilizes the transmitted light of the FBG as self-injection feedback for single-longitudinal-mode (SLM) oscillation is proposed and demonstrated. This

WuT data sheet: Universal FO Interface



RS232/RS422/RS485

Transmit serial data over very long distances The model 81215 Interface features a selectable RS232, RS422 or RS485 interface which the Converter changes into a universal optical port for single-mode



Analog Audio Over Fiber Extender , Mono Stereo

Analog audio over fiber extender supporting 2 to 32 channels of unbalanced audio transmission over long distances up to 20 km on single-mode fiber. Reliable, low

Single-Mode-Fiber Design for Low Latency and Low Loss

Low-latency transmission is necessary for optical transmission systems, and a reduction in propagation delay of 1 us in an optical fiber is effective. We investigated the tradeoff between



Mode-resolved picosecond single-photon polarimetry maps modal

Single-photon real-time imaging reveals the polarization dynamics of spatial modes in few and multimode optical fibres, enabling mode-resolved polarimetry and visualization of complex fibre



(PDF) Polarization noise in single mode fibres and its reduction by

The polarization noise, originating from the combination of single mode fibres and diffraction gratings, is investigated experimentally.

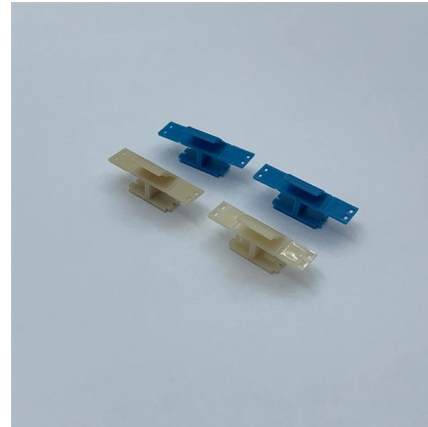

Observation of modal noise in single-mode fiber transmission

Modal noise has been observed in overmoded short fiber sections and transmitter pigtails resulting in performance degradation in a single-mode fiber transmission system.

Modal noise in single-mode fibers

Physical distortions of the fiber before a connector cause modal noise. It is shown that the signal-to-noise ratio caused in this way is of the same order of magnitude as in suitable multimode-fiber systems.



Home , Hamamatsu Photonics

The official website of Hamamatsu Corporation whose mission is to advance science and industry through photonic technologies. Our products include optical sensors



Modal Noise In Single-Mode-Fiber Communication System

The amount of modal noise that appears in a single-mode-fiber communication system depends on the coherence properties of the laser transmitter, the length of the noise-generating fiber present in the



30 dBm single mode fiber-coupled semiconductor optical amplifier at

Watt-class semiconductor optical amplifiers (SOAs) at 1550 nm are an attractive alternative to replace erbium-doped fiber amplifiers (EDFAs) in various applications including remote sensing, optical

Contact Us

For datasheets, pricing, or custom high-speed optical interconnect solutions, please visit:
<https://www.syropy.com.pl>