

Multi-core optical cable stripping technology standard





Multi-core optical cable stripping technology standard



How to Choose the Right Fiber Stripper for Your Fiber

Discover the critical role of fiber strippers in maintaining cable integrity, splicing quality, and minimizing signal loss. Learn key features for selection,

World's First Standard Cladding Diameter 19-core Optical Fiber with

A group of researchers from the National Institute of Information and Communications Technology (NICT, Japan) and Sumitomo Electric Industries, Ltd. (SEI, Japan) in collaboration with



Fiber Optics Stripping, Cleaving, Splicing, Recoating,

The CMS is specifically designed to maintain production level repeatability for multi-kilowatt class high-power fiber combiners and other fused optical components.

Optical Fiber Strippers

Our range of optical fiber strippers extends from handy, pocket-sized tools to fully automated plasma-assisted stripping machines. In addition to a wide range of



Automatic Multifunctional Multi Cable Core Wire

AOFC-8030H is a fully automatic inner and outer sheath stripping machine designed for cutting and stripping the outer and inner fiber of multi-core cables. It supports



Quickstart Guide: CresFiber® 8G Multimode Fiber Termination

The items required to terminate CresFiber 8G multimode fiber optic cable are shown below.



Fiber Strippers

This unique solution provides unmatched flexibility for various optical fiber diameters, making it a versatile choice for your fiber optic stripping needs. At 3SAE, we hold





Research on the Automatic Stripping Technology of Cable Sheath and

Abstract This paper aims to improve the precision and efficiency of cable sheath and shield layer stripping by integrating multi-sensor systems. The proposed system combines optical, temperature,

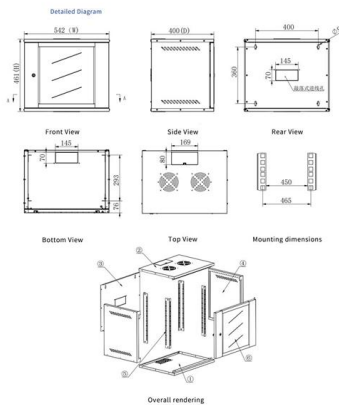

Applications and Development of Multi-Core Optical

They began exploring how to achieve multiple optical transmission channels in a single fiber. However, the technological limitations and immature

What Is Multi Core Optical Fiber?

Conclusion Multi-core optical fiber is a breakthrough in optical networking that packs multiple cores into one fiber, enabling tremendous capacity gains via spatial



Optical fiber

Optical fiber A bundle of optical fibers A TOSLINK fiber optic audio cable with red light shining in one end and out the other An optical fiber, or optical fibre, is a



Applications and Development of Multi-Core Optical Fibers

Abstract The rapid development of information and communication technology has driven the demand for higher data transmission rates. Multi-core optical fiber, with its ability to transmit



Multicore Fiber

1.3 Multicore fibers An MCF is an optical fiber that includes multiple cores in one common cladding. MCFs offer more degrees of freedom in fiber parameters than single-core fibers, which implies that

Professional Stripper Fiber Optic Tool: Precision Coating Removal for

High-precision stripper fiber optic tool featuring advanced coating removal technology, ergonomic design, and versatile compatibility for professional fiber optic cable preparation and installation.



Reaching the pinnacle of high-capacity optical

Multi-core fiber technology a Comparison of standard SMF, multi-core, and MMF technologies, constrained to standard cladding diameter fibers. b



Research on the Automatic Stripping Technology of

The proposed system combines optical, temperature, and pressure sensors to monitor and control key parameters in the stripping process.



Multi-Core Fiber: How It's Set to Revolutionize the

Multi-core fiber (MCF) is emerging as a groundbreaking technology poised to transform the optical networking industry. By packing multiple optical

Advanced Photonics Coalition Multi-Core Fiber Standards

To overcome these challenges, the Advanced Photonics Coalition Multi-Core Fiber Standards Working Group is comprised of leading industry companies combining



Multi-core Fiber Technology

Multi-core fibers are expected as a good candidate for overcoming the capacity limit of a current optical communication system. This chapter describes the recent progress on the Multi-core fibers



Multi-core Fiber Technology

Multi-core fibers are expected as a good candidate for overcoming the capacity limit of a current optical communication system. This chapter describes



Professional Stripper Fiber Optic Tool: Precision Coating Removal for

This specialized instrument employs advanced mechanical and thermal stripping technologies to ensure clean and damage-free preparation of fiber optic cables for splicing or termination processes.



Sumitomo Electric and NICT Develop the World's First

Sumitomo Electric Industries, Ltd. and the National Institute of Information and Communications Technology (NICT) have developed a randomly



Multicore Cable Stripping & Crimping Machine , Efficient

Experience efficient wire processing with the HWN-809: your one-step solution for stripping and crimping multi-core cables,featuring easy setup and high output.



Reaching the pinnacle of high-capacity optical transmission using a

Space division multiplexing offers increased capacity over current fiber networks. Here, the authors demonstrate petabit/s transmission in a standard-sized 19-core multi-core fiber, while



Stripping Cleaning and Fiber Prep Automation

Our products ensure efficient, precise fiber preparation, helping enhance fiber optic network performance and reliability.

Novel 19-Core Fiber Hits 1.7 Petabits per Second

MFC with standard cladding, on the other hand, remains compatible with commonly used optical components, equipment, and systems, and can take

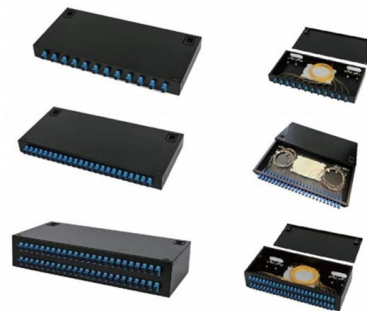

Standard cladding diameter multi-core fiber technology

We show progress of standard 125 um-cladding multi-core fiber (MCF) technology for cable deployment and its standardization. Its application space and geometrical requirements are described by



Research on the Automatic Stripping Technology of

Optical sensors are used to track the relative position of the cable and tool, while temperature sensors monitor the heat generated during stripping to



The Ultimate Optical Fiber Stripper Guide

Adjustable and Specialized Optical Fiber Stripper Models While most applications use standard fiber sizes, some projects may involve non-standard or

Contact Us

For datasheets, pricing, or custom high-speed optical interconnect solutions, please visit:
<https://www.syropy.com.pl>