

Monaco Co-packaged Photonics 2 5G





Monaco Co-packaged Photonics 2 5G



Co-packaged optics (CPO): status, challenges, and solutions

This section mainly discusses 2D/2.5D/3D silicon photonic co-packaging module developed by IMECAS, 2D MCM photonic module package issues, and the challenges of silicon photonic wafer-level

Co-packaged datacenter optics: Opportunities and

High-capacity, high-density, power-, and cost-efficient optical links are undoubtedly of critical importance for datacenter infrastructure. However, the



The Rise of Co-Packaged Optics (CPO): How It Redefines Data

Introduction: Why Co-Packaged Optics Is Transforming Networks As bandwidth demand accelerates--driven by AI clusters, 5G deployment, and hyperscale data centers --traditional

The Rise of Co-Packaged Optics (CPO): How It Redefines Data

Discover what Co-Packaged Optics (CPO) is, its architecture, benefits, challenges, and future trends in AI-driven data centers and high-speed networks.

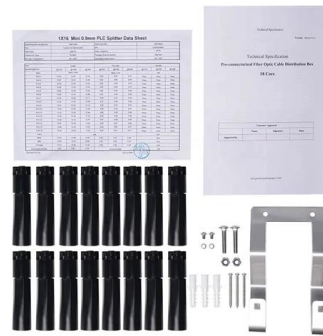

Co-packaged optics in radio-access networks

Most of the technologies developed for co-packaged optics (CPO) in data centers have strong reuse potential in radio-access networks (RANs) because they are based on cost-effective

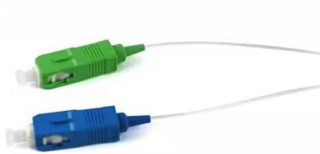

Roadmapping the next generation of silicon photonics

For co-packaged optics (CPO) to succeed, high-performance computing to scale 22, and disaggregated computing to become a reality 42,



Silicon photonics for high-speed communications and photonic signal

Leveraging on the mature processing infrastructure of silicon microelectronics, silicon photonic integrated circuits may be readily scaled to large volume production for low-cost high





Co-packaged optics are inching closer to

Silicon photonics is now a well-established technology and market for optical transceivers. In 2021, more than 9 million silicon photonic transceivers were shipped for datacenters.



What is Co-Packaged Optics?

Learn how co-packaged optics is reshaping data center networks by slashing power use and unlocking massive bandwidth for next-gen AI performance.

The advent of co-packaged optics (CPO) in 2025

Co-packaged optics (CPO)--the silicon photonics technology promising to transform modern data centers and high-performance networks by

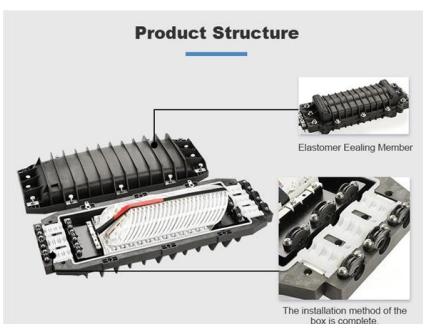

Co-packaged optics (CPO): status, challenges, and solutions

Co-packaged optics (CPO) is a disruptive approach to increasing the interconnecting bandwidth density and energy efficiency by dramatically shortening the electrical link length through advanced



Co-Packaged Optics - List of Examples - Ansys Optics

Ansys Lumerical and Zemax toolsets provide the best-in-class solutions to simulate and design complete optical coupling systems for co-packaged optics and other integrated photonics applications.

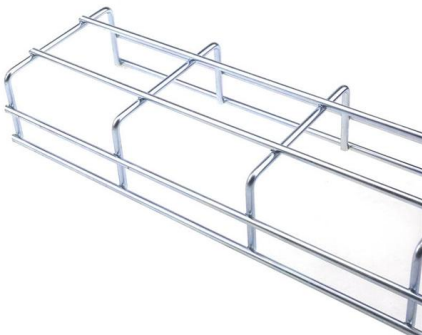

Co-packaged optics: higher data rates increase

Our customers are building 2.5D heterogeneous, integrated, co-packaged devices using chips connected to the package through fine-pitch

Co-packaged optics (CPO): status, challenges, and

Co-packaged optics (CPO) is a disruptive approach to increasing the interconnecting bandwidth density and energy efficiency by dramatically



Silicon Photonic Micro-Transceivers for Beyond 5G

Here, we report on the design and performance of a silicon photonic micro-transceiver required to operate in 5G and 6G environments at high ambient



CPO (Co-Packaged Optics Solutions) , ASMPT SEMI

It achieves this by significantly reducing electrical interconnect lengths through advanced packaging and simultaneously optimizing electronics and photonics.



Co-Packaged Photonics For High Performance Computing: Status

Photonics die or integrated photonics modules co-packaged with compute engines have the potential to deliver significant improvements in power, bandwidth and reach needed to meet the computing and

Silicon photonics and co-packaged optics at the heart of

With AI reshaping data infrastructure, silicon photonics and co-packaged optics represent critical enablers of tomorrow's data center. Yole



arXiv e-Print archive

The paper discusses future advancements in silicon photonics technology.



Why Co-Packaged Optics Are a Game Changer , RealIZM

This section mainly discusses 2D/2.5D/3D silicon photonic co



Understanding In-Package Optical I/O Versus Co

At the same time, there is a lot of confusion -- some inadvertent, some perhaps intentionally sown -- regarding the differences between interconnect

Electronic Chip Package and Co-Packaged Optics

Meanwhile, the optical module, enabled by silicon photonics, is now treated similarly to electronic chips, and advanced co-packaged optics (CPO) is



Co-packaged optics are inching closer to

Chiplets enabled by silicon photonics Industry Event: Co-Packaged Optics and Silicon Photonics for Data Center Applications



2.5D Heterogeneous Integration for Silicon Photonics Engines

In this paper, we discuss a packaging technique where 2D structures, on a common silicon photonics interposer/substrate, are interconnected with other silicon devices via a package substrate. This



Contact Us

For datasheets, pricing, or custom high-speed optical interconnect solutions, please visit:
<https://www.syropy.com.pl>