



**Syropy AI Connectivity**

# **Low Temperature Resistance Selection Guide for Power Grid- Grade Optical Receivers**





## Low Temperature Resistance Selection Guide for Power Grid-Grade

---



### CMOS Low-Power Optical Transceiver for Short Reach

After outlining the design principles for low-power optical transmitter (Tx) and receiver (Rx) design, we present a comprehensive design of a low

### Highly-Sensitive Integrating Optical Receiver With Large PIN Photodiode

Abstract--This paper presents a highly-sensitive monolithic op-toelectronic receiver in 180 nm CMOS. An integrating front-end with noise matching via an negative Miller capacitance is proposed, to

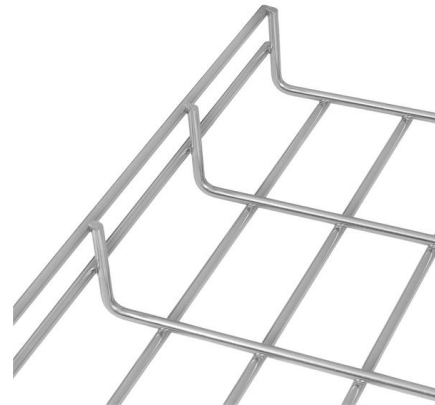

### Optical & IC Products

Semtech's Tri-Edge technology offers the only analog CDR solution for optical modules capable of meeting the low power, low cost requirements needed for data center PAM4 optical interconnects.



### Optical Receivers: A Comprehensive Guide

Explore the world of optical receivers and their significance in optical communications, including their types, applications, and key considerations.



### Low-Power CMOS Receivers For Short Reach Optical Communication

Abstract--Emerging applications for short-reach optical communication require low-power receiver circuits in nanoscale CMOS technologies. An analysis of optical receivers with broad-band input



### Optical Receiver

In this section, we discuss techniques to characterize optical receivers, with a focus on the wideband characterization of their frequency response.



### A Compact Integrated Receiver Optical Sub-Assembly With High

A 25Gb/s guardring-free planar AllnAs avalanche photodiode (APD) and 100-Gb/s APD receiver optical sub-assembly (ROSA) employing a quasi-collimated beam for reducing the optical



### Optical Transceiver Operating



## Temperature: A Comprehensive Guide

Optical transceivers play a crucial role in modern telecommunications and data networking systems, facilitating the transmission of data over optical fibers. One often-overlooked factor that



## Receiver Sensitivity vs Minimum Receiver Power: A Deep Dive into

Discover the key differences between receiver sensitivity and minimum receiver power, and learn how these metrics influence optical transceiver selection, signal integrity, and link

## Microsoft PowerPoint

Optical Receivers Optical receivers convert optical signal (light) to electrical signal (current/voltage) Hence referred 'O/E Converter' Photodetector is the fundamental element of optical receiver,

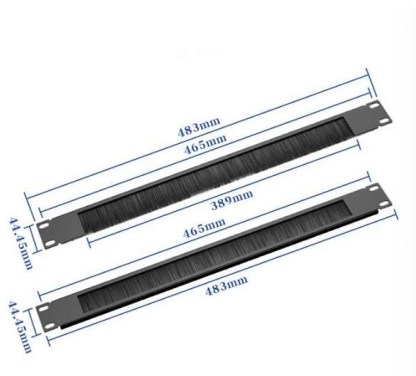

## Development of High Sensitivity SWIR APD Receivers

Together with the low temperature dependence on the gain, Spectrolab Gen 3 APDs are capable to operate in a wide range of temperature and provide near minimum NEPs over the range.



## Optical Receivers: The Ultimate Guide

Discover the fundamentals and advancements in optical receivers, crucial for high-speed data transmission in optical communications.



### Optical Receiver

Optical devices, a transceiver chip, and package structure are key in attaining low power, high speed, and a small footprint for an optical transceiver. Moreover, the transceiver chip has not only analog FE

### Advanced optical modular sensor platform GridAdvisor Insight m410

oltage and current measurement, as well as vibration and temperature condition monitoring. The m410 has four modular bays that allow for any sensing combination, including sensing of voltage, curren.

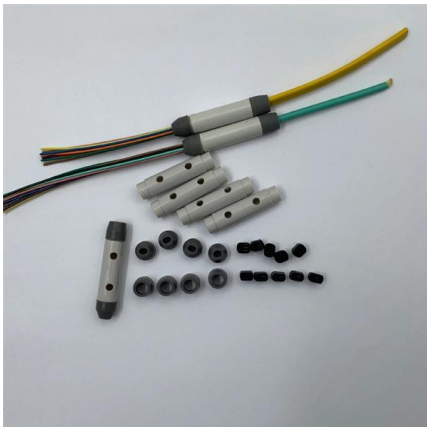

### Chapter 9 Optical Receiver Design

Traditionally, optical receivers have been working in continuous (cw) mode. However, with the advent of fiber-to-home and PON networks, burst mode re-ceivers have become increasingly important.



## The tradeoff between noise, data rate, and power consumption of

The inverter-based shunt-feedback transimpedance amplifier (TIA) has become an essential building block for high-speed receivers for optical interconnects in advanced technologies due to its low



## Optoisolation and Optical Sensor Products Selection Guide

Products include the lowest power dissipation with input current as low as 40 uA, high-speed digital optocouplers operating at up to 50 Mbaud, propagation delays as low as 22 ns, and 3.3V JEDEC



## 0291 Janos catalog Reference.F

Magnesium Fluoride is a birefringent material and this aspect should be taken into consideration before selection of this material in an optical design. Janos uses only VUV grade material, with the C-axis



## An ultra-low power 4x28Gbps linear optical receiver for short-reach

This work proposes a DSP or Retimed-free linear optical receiver scheme employing a commercially available ultra-low-power transimpedance amplifier (TIA) die. Through systematic





## Polarizer Selection Guide

Polarizer Selection Guide Authors: Stefaan Vandendriessche For more information on polarization read Introduction to Polarization. Polarization is an important



## Operating Temperature Range of Optical Transceivers Explained

Understand the operating temperature range of optical transceivers, including commercial (0°C-70°C), extended (-20°C-85°C), and industrial (-40°C-85°C) grades.



## Fiber Optic Receivers Selection Guide: Types, Features, Applications

Fiber optic receivers convert light signals into electrical signals for use by equipment such as computer networks. These electro-optical devices consist of an optical detector, a low-noise amplifier, and

### PRODUCT DETAILS

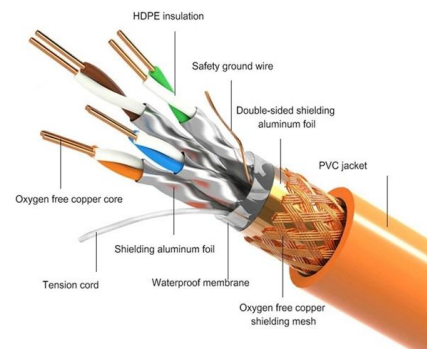

## Optical Mirror Selection Guide

Mirrors are probably the most commonly used optical elements in your lab, and their quality, performance, and reliability are key to the success of your experiment.



### High Density Optical Platform

The optical platform WISI Optopus is notably flexible and serves high-density needs for all kinds of RF optical networks. The platform is engineered to perform in a large number of environments, such as



### Low-power CMOS receivers for short reach optical communication

Emerging applications for short-reach optical communication require low-power receiver circuits in nanoscale CMOS technologies. An analysis of optical receivers with broadband input



### Optical Receivers , part of Fiber-Optic Communication Systems

Summary

This chapter introduces the basic concepts related to such photodetectors and discusses several types of photodetectors used for optical receivers. It also introduces basic concepts such as



### Chapter 9 Optical Receiver Design

Receiver Design 9.1 Introduction In this chapter we consider issues related to the design of optical receivers. As signals travel in a fiber, they are attenuated and distorted, and it is the function of the



## Contact Us

---

For datasheets, pricing, or custom high-speed optical interconnect solutions, please visit:

<https://www.syropy.com.pl>