

Ireland After-Sales Service for PAM4 Optical Receivers

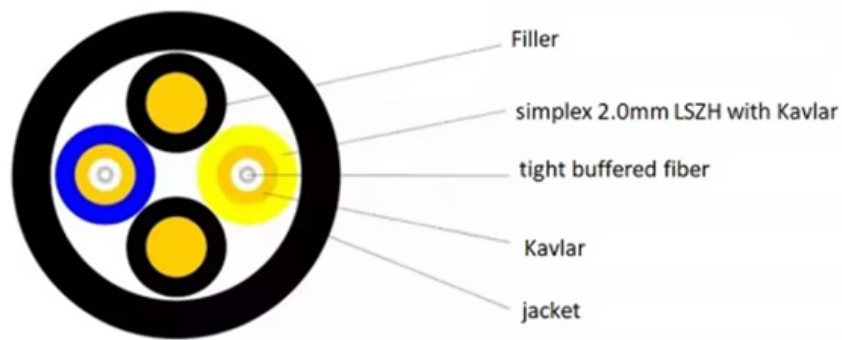



Ireland After-Sales Service for PAM4 Optical Receivers



Arista OSFP-800G-VSR8 OSFP 8x100G SR8 Transceiver , FiberMall

Arista OSFP-800G-VSR8 Compatible OSFP 8x100G SR8 PAM4 Optical Transceiver Module (850nm MTP/MPO-16 MMF 100m OM4 with FEC DDM) OSFP 8x100G SR8 transceiver modules are

Optical DSP

Credo's extensive optical portfolio includes DSPs for 50G, 100G, 200G, 400G, 800G and 1.6T PAM4 optical transceivers and active optical cables. Our products meet



aw100-g_product_brief_0_5_3

The AW100-G is a Gearbox/Retimer Digital Signal Processor (DSP) for PAM4 optical applications. The gearbox features an 8x50G interface on the host side and a 4x100G interface on the line side. The

Transimpedance Amplifiers

Our portfolio includes linear TIAs for coherent and PAM-4 receivers and limiting TIAs for NRZ based receivers. These parts feature market leading gain, noise performance and power dissipation.



PAM4: For Better and Worse

In our righteous zeal to maintain interoperability, the early PAM4 standards made these restrictions to account for receivers based on a minimal



aw100-r_product_brief_0_5_3

8x100G<->8x100G PAM4 Optical DSP Retimer
The AW100-R is a Digital Signal Processor (DSP) for PAM4 optical applications. On the host interface, the device can equalize up to 27dB of loss



A Low Noise 28Gbaud/s Linear PAM4 Receiver Front

Abstract and Figures This paper presents a low noise 28 Gbaud/s linear receiver front-end for fourth-order pulse amplitude modulation (PAM4)



PAM4 Analysis Software Instruction Manual

Eye diagram analysis of a PAM4 signal PAM4 builds on the power of Teledyne LeCroy's SDA III software, shifting the emphasis from multi-lane analysis to multi-eye analysis of PAM4 signals. Like



PAM4 Software für neue OIF-CEI

Als Vorreiter auf dem Gebiet der Signalgüte arbeitet Tektronix mit Ingenieuren und Normungsorganisationen aus dem Bereich der Datenkommunikation Hand in Hand, um gemeinsam

VPIphotonics - VSB 100G PAM-4 Optical Interconnect

In this example, a 53 Gbaud PAM4 signal is generated electrically, and raised-cosine pulse shaping is used with a roll-off factor of 0.01 to limit the electrical spectrum to



Keysight Technologies PAM-4 Design Challenges and the Implications on

NRZ (Non-Return-to-Zero) uses a currently available technology and will continue a linear evolution from 100G (25/28G, 4 lanes) to 400G (56G, 8 lanes). From a time domain perspective,



PAM4 Signaling in High Speed Serial Technology: Test

We'll see that PAM4 signal analysis borrows a great deal from the jitter and noise analysis developed for PAM2-NRZ and that PAM4 technology at 25+ GbD will continue to benefit from the innovations that

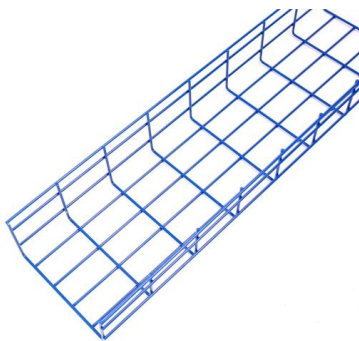

Marvell Ara PAM4 Optical DSP

The Marvell Ara PAM4 DSP is a next generation solution for GenAI and cloud datacenter interconnects utilizing pluggable transceivers. Ara features eight 200Gbps/channel PAM4 host electrical interfaces,

What is PAM4 Modulation and How is it Transforming

What is PAM4 Modulation and How is it Transforming Optical Networking? In this blog, we take a higher-level look at PAM4, the modulation scheme that makes

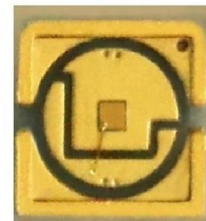

Demonstration of wavelength tunable optical modulation format

In this paper, we demonstrate optical format and wavelength conversion of 20 and 30 Gb/s QPSK-to-PAM4 by using two nonlinear wave mixing stages . We manipulate the input



8x100G FR PAM4 1310nm Dual MPO-12 2km SMF Transceivers

OSFP 8x100G FR transceiver modules are designed for 800 Gigabit Ethernet links over 2km of single-mode fiber. The module has 8 independent channels of electrical input/output, each operating at up



Update on component and channel characterization for optical 200G

High bandwidth EML & PD+TIA performance was updated. An EOL sensitivity of -5dBm per lane at the (stressed) receiver interface is feasible for 4x200G based IM-DD solutions. The CD penalties are



PAM4 Basics: Modulation, Signaling and Encoding

Explore The Fundamentals of PAM4 Modulation, Signaling and Encoding. Plus, Compare PAM4 to NRZ and Find Helpful Eye Diagrams. Visit To

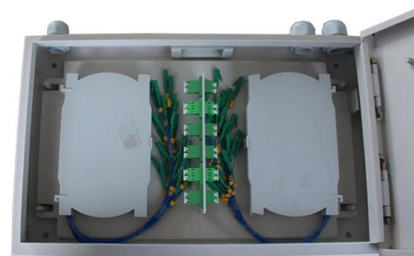

PAM4 Technology: Revolutionizing Optical Transceiver

Introduction In the rapidly-evolving world of optical communication, PAM4 technology has emerged as a game-changer. PAM4 stands for Pulse



AN 835: PAM4 Signaling Fundamentals

This application note explains PAM4 theory and its operation. It describes NRZ and PAM4 fundamentals, standards using PAM4 coding schemes, and CEI-56G Interconnect reaches and



30GHz Sampling Scope

As a low-noise, high-sensitivity calibrated reference receiver (compliant to industry standard tolerances), DCA6201 support an extremely high dynamic range, both multimode and single-mode signals at

PAM4 Optical Modulation: Meeting the Demands of Increasing

Consequently, the industry has turned to PAM4 modulation to realize ultra-high-bandwidth network architectures. PAM4 is an optical modulation technique that allows for higher data rates and



PAM4 Optical Transceiver

Hyper Photonix offers a comprehensive range of high-performance NRZ and PAM4 optical transceivers designed to serve the varying speed requirements within the bandwidth-intensive landscape of

Design and Implementation Scheme of



QSFP28 Optical

Experiments were conducted using an avalanche photodiode (APD) optical receiver for 40 and 60 km long-distance PAM4 signal transmissions [6, 7,



Pam4 Optical Transceiver Market Report , Global Forecast From 2025

The PAM4 Optical Transceiver market is segmented by component into Transmitter, Receiver, and Transceiver Module. Among these, the Transceiver Module segment is anticipated to dominate the

Analyzing 26-53 GBaud PAM4 Optical and Electrical Signals

Introduction PAM4 (4-level pulse amplitude modulation) is being adopted in many applications at data rates of 50 Gb/s and higher. By encoding two bits in each symbol, PAM4 signals



LightCounting :: PAM4 DSPs will Double the Market for IC Chipsets

LightCounting updates its forecast for sales of Coherent and PAM4 DSP chipsets. The market for optical interface IC chipsets is reaching an inflection point now and is projected to grow at 20% CAGR in



50G PAM4 Technical White Paper

This proposal was accepted after thorough discussion, technical analysis, and argumentation. 400GBASE-LR8/FR8 is the first standard that applies PAM4 at the optical layer.



Cisco Compatible Coherent VCSEL & Broadcom DSP

Cisco Compatible Coherent VCSEL & Broadcom DSP 400GBASE-SR4 OSFP PAM4 850nm 100m MTP/MPO-12 APC MMF Optical Transceiver Module NADDOD

PAM4 for 400G Optical Interfaces and Beyond (Part 1)

This blog walks you through the basics of PAM4 modulation for current and next-generation optical transceivers.



What Is PAM4? What Are the Advantages of PAM4?

Four-level pulse amplitude modulation (PAM4) uses four different signal levels for signal transmission, doubling the signal transmission efficiency compared with the traditional non-return-to



Feed-Forward Control of PAM4 CTLE for Optical Receivers Based on

PAM4 EDC for an optical network receiver is studied. In a conventional EDC, the amount of compensation is adjusted by a feedback controller, thus, it takes time for the packet response. We



DSA8300 Datasheet

Optical modules that support optical data rates from 155 Mb/s to 10 Gb/s to 40 Gb/s to 100 Gb/s to PAM4 for 50G/100G/200G/400G Optical reference receivers (ORR) 3 support specified requirements

Halo® Next Gen Mid-Board Optical Transceivers

Samtec's Halo® mid-board optical transceivers (IN DEVELOPMENT) are designed for next gen embedded applications demanding 56/112 Gbps PAM4 performance



PAM4 Optical Transceiver

PAM 4 and NRZ Optical Transceivers Hyper Photonix offers a comprehensive range of high-performance NRZ and PAM4 optical transceivers designed to serve the varying speed requirements



PAM4 and Coherent DSPs

This report analyses the market for semiconductor IC chipsets used in optical transceivers, active cables, and related products. The chipsets include laser drivers, TIAs and in

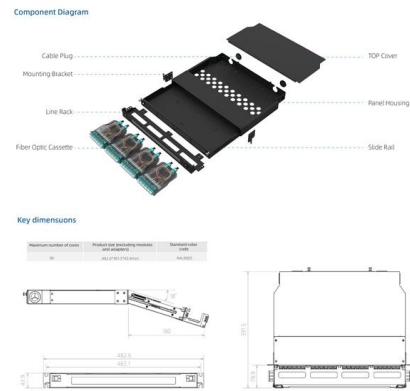

Electrical Equalization Analysis of PAM-4 Transmission

Inclusive and intensive performance analysis of electrical equalizers in a short-reach optical system using four-level pulse amplitude modulation (PAM)

Optical Bandwidth Requirements for NRZ and PAM4 Signaling

WHITEPAPER There is confusion about Optical Bandwidth and Electrical Bandwidth of optical channels and how these terms relate to Optical Reference Receivers (ORRs). PAM4 signaling has further



Contact Us

For datasheets, pricing, or custom high-speed optical interconnect solutions, please visit:
<https://www.syropy.com.pl>