

How to adjust a hybrid fiber optic sensor





How to adjust a hybrid fiber optic sensor



High sensitivity fiber optic temperature sensor composed of two

A high-sensitive fiber-optic Fabry-Perot sensor with parallel polymer-air cavities based on Vernier effect for simultaneous measurement of pressure and temperature.

Fiber Optic Sensors: Fundamentals, Principles & Applications

Radiation absorption excites an orbital electron to a higher energy level. Radiation absorption creates electronic excited states that are trapped by localized defects for extended periods of time. Heating

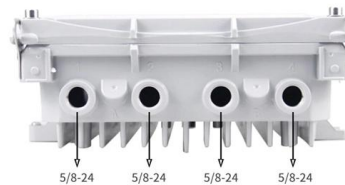

Digital Fiber Optic Sensor/Amplifier Wiring and Setting

Fiber optic sensor has a digital LED display and 3-wires out lines. Digital fiber optic sensor is used for detection, counting and position control in the occasions with high accuracy requirement



Hybrid Systems Combining Traditional and AI-Enhanced Optical Fiber Sensors

Integrating AI with optical fiber sensors allows a hybrid system that enhances strength for detecting various physical parameters such as intensity, data transmission, wavelength, and phase. These



Fiber Optic Sensor : Types, Working, Interfacing & Its

The fiber optic sensor working principle is that transducer changes some optical fiber system parameters like wavelength, intensity, phase,

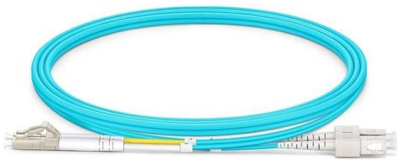

Hybrid Fiber-Optic Sensors , Springer Nature Link

Moreover, specially designed microstructured optical fibers are able to achieve high birefringence that can suppress the output inaccuracy induced by polarization crosstalk meanwhile



How to adjust optical fiber sensor

No description has been added to this video. Enjoy the videos and music you love, upload original content, and share it all with friends, family, and the world on .



Hybrid Plasmonic Fiber-Optic Sensors

In this review, the background and the state-of-the-art of SPR/LSPR fiber-optic sensors will be reviewed. More importantly, the aforementioned emerging hybrid fiber-optic plasmonic sensing solutions will be

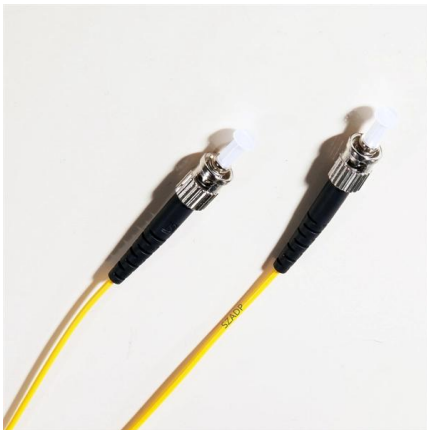

DIGITAL FIBEROPTIC SENSOR TRAINING GUIDE

When using a thru-beam type sensor, the light is completely blocked if the workpiece is larger than the fiber strand diameter (lens diameter). Fiber strand diameter (Lens diameter) Therefore, the optimal

FS-N Series Setting Guide 468GB

For precautions and operation details, refer to the instruction manual included with the product.
*1 This is a channel switch on 2-output types. This is not equipped with the 0-line type. *2 Press and hold the



Hybrid fiber interferometer sensor for simultaneous measurement of

A hybrid fiber interferometer sensor is proposed and demonstrated for simultaneous measurement of strain and temperature with insensitivity to external refractive index. This sensor



Fiber-optic sensor

A fiber-optic sensor is a sensor that uses optical fiber either as the sensing element ("intrinsic sensors"), or as a means of relaying signals from a remote sensor to the electronics that process the signals



Fiber Optic Sensors: Types, Working Principle

This article explores the different types of Fiber Optic Sensors, their working principles, and various applications. We'll delve into Intrinsic, Extrinsic, and

Fiber Optic Sensors: Fundamentals, Principles & Applications

Optical Fiber (Transmission Medium, Sensing Element) Light modulated due to interaction with parameter of interest (Measurand)



Recent advancements and future challenges in hybrid optical fiber

Therefore, generating VE with the Hybrid interferometers can significantly enhance the sensitivity and resolution of the conventional optical fiber sensors. Typically, Vernier calliper uses the



Hybrid Fiber Optic Sensor Systems in Structural Health

This paper presents an overview of hybrid fiber-optic sensing systems based on scattering techniques, fiber Bragg gratings, interferometric

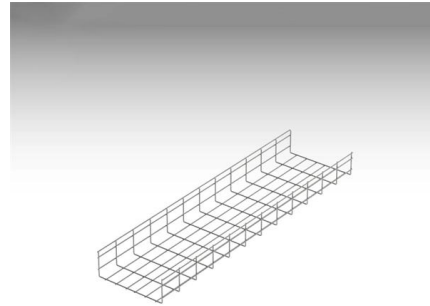

Grid Cable for marine and offshore applications

DIGITAL FIBEROPTIC SENSOR TRAINING GUIDE

Make sure that the light enters the receiver with the translucent workpiece present and that the sensor turns ON and OFF by placing your hand between the sensor head and the workpiece.



Hybrid Plasmonic Fiber-Optic Sensors

Among various sensing mechanisms, plasmonics based fiber-optic sensors provide remarkable sensitivity benefiting from their outstanding



Hybrid Fiber Optic Sensor Systems in Structural Health Monitoring in

'Smart' structural health monitoring of composite materials with optical fiber sensors is becoming more and more important, especially in the aviation industry. This paper presents an overview of hybrid



Hybrid Fiber-optic Sensor for Simultaneous Seawater

Abstract In this letter, we propose a compact hybrid fiber-optic sensor for seawater temperature and salinity simultaneous measurements.



Digital Fiber Optic Sensor/Amplifier Wiring and Setting

When external physical quantities change the propagation characteristics of the optical fiber, the detector captures these changes and

INTELLIGENT DIGITAL FIBER OPTICAL SENSOR

To connect coaxial reflector optical fiber unit to amplifier, please connect the single core 2 Wh

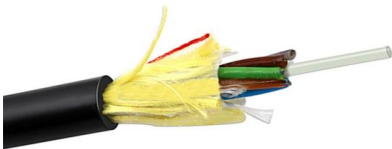

Hybrid Plasmonic Fiber-Optic Sensors

Moreover, specially designed microstructured optical fibers are able to achieve high birefringence that can suppress the output inaccuracy induced by



How to Adjust

How to Adjust - Set up Keyence Fibre Optic Teach Sensor on JDA Filling & Capping Machines For sales inquiries or questions about our machinery please contact our office.

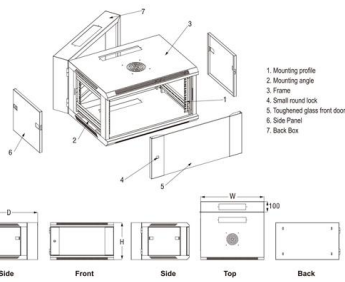

Fiber Optic Sensing: A Beginner's Guide

Fiber optic sensing relies on light rays within optical fibers to detect changes in temperature, strain, and other environmental parameters. Utilizing the

ODiSI Fiber Optic Sensor Installation Guide

This Application Note is intended to guide users of Luna's High Definition Fiber Optic Sensing (HD-FOS) system (the ODiSI) through the simple process of mounting a fiber sensor onto the surface of a test



Hybrid Distributed Optical Fiber Sensor for the Multi

In this review, we summarize and discuss recent advances in the study of hybrid distributed optical fiber sensors for multi-parameter measurements. This work is



Digital Fiber Optic Sensor/Amplifier Wiring and Setting

Fiber optic sensor has a digital LED display and 3-wires out lines. Digital fiber optic sensor is used for detection, counting and position control



Fiber Optic Sensor Installation Methods

This article provides an overview of fiber optic sensor installation methods to help readers understand how a high-resolution distributed sensing system can be

Hybrid Fiber Optic Sensor, Based on the Fabry-Perot

Abstract Herein we design a fiber sensor able to simultaneously measure the temperature and the pressure under harsh conditions, such as strong

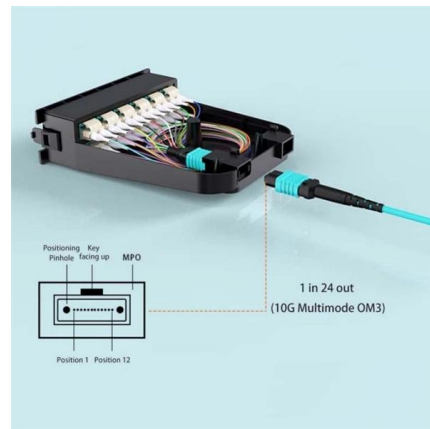

Hybrid fiber-optic DC current sensor using parallel MZI-FPI

This work introduces a novel hybrid fiber-optic DC current sensor combining a conductive silver adhesive-coated Mach-Zehnder interferometer (MZI) with a parallel Fabry-Perot interferometer



Contact Us

For datasheets, pricing, or custom high-speed optical interconnect solutions,
please visit:

<https://www.syropy.com.pl>