



# How much does fire-resistant cable tray cost now



CORE

Long transmission distance



JACKET

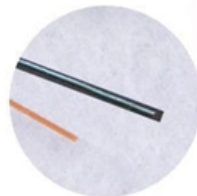

STEEL

High strength





## How much does fire-resistant cable tray cost now

---



### Fire Resistance Testing of Cable Trays: Key Standards

Fire Resistance Testing of Cable Trays ensures they don't fuel fires or emit toxic smoke. Learn key standards, testing methods, and safety tips.

### How to Choose Fire Resistant Cable Tray for

Selecting the appropriate fire protection system for fire resistant cable trays in high-stakes projects--especially in regions like the Middle East with

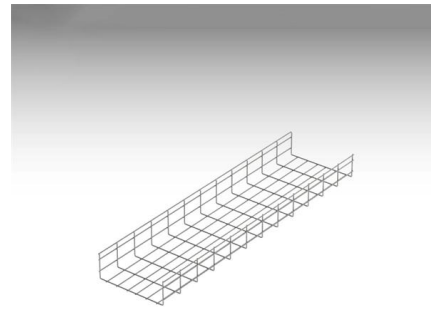

Grid Cable for marine and offshore applications

### Fire resistant cable tray , Hermi-solutions

Cable trays are intended for the construction of fire-resistant cable paths. Do you need help with your purchase? The HERMI team will be happy to advise you and



### Fire-resistant cable tray

Find out all of the information about the NIEDAX product: fire-resistant cable tray . Contact a supplier or the parent company directly to get a quote or to find out a

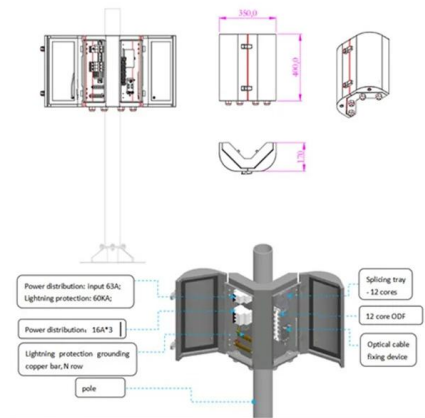

### Cable Tray Covering & Fire Protection

Cable Tray Covering & Fire Protection. FireResistant Solutions provides cable tray covering and fire-protection systems designed to safeguard electrical and data infrastructure in commercial and



### FireMaster Cable Tray Wrap

FireMaster ® products insulate cable trays carrying instrument control cables to ensure that the cables can operate long enough to allow process shut down

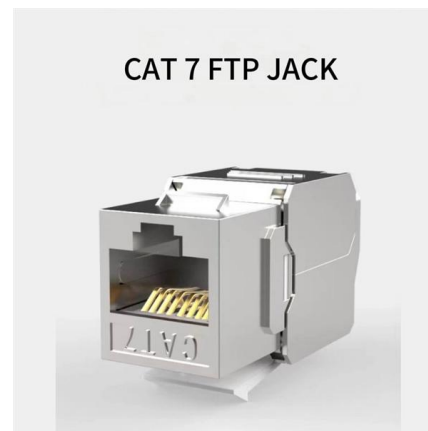

### Cable Trays, Fire safety solutions

The stock and the price of the product are for information only and may change during the day.





## Fire Safety Considerations for Cable Trays: Protecting

Learn about essential fire safety measures for cable trays to safeguard your electrical infrastructure. Discover expert guidance and solutions



### **FIRE RESISTANT PROOF CABLE TRAY, DIN STANDARD E90**

Cablofil fire resistant and fire proof cable trays are increasingly specified in the construction, power, oil, gas, petrochem, rail and utilities industries. Cablofil cable tray has been successfully tested and

### **Trunking and cable tray protection**

Our range of trunking and cable tray protection products provide effective fire protection for pipes, cables and trunking within floors, walls and ceilings.



### **Cable Tray Covering & Fire Protection**

What We Do Install fire-resistant wraps, blankets, and coverings around cable trays and conductors. Build fire-rated enclosures around tray runs, transitions, and penetrations to block flame and smoke



### **Advanced Fire Resistant Cable Tray , Maximum Heat**

Top-quality fire resistant cable tray with N1 fire rating, 5-12 mm fireproof core, superior heat insulation, flame protection, and 60-min fire resistance.

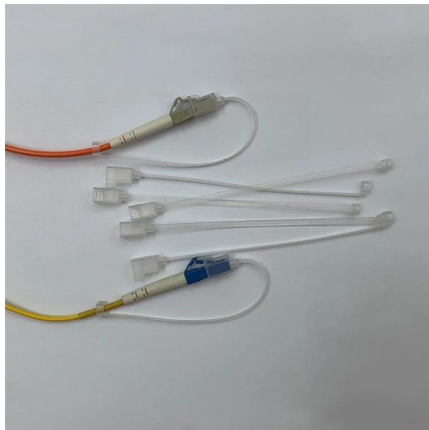

### **Benarx Epoxy Cable Tray for passive fire protection**

Benarx Epoxy Cable Tray protects critical power and signal cables in case of fire, maintaining their integrity and functionality. The products is known for its

### **Fire Rated Cable Tray, Heavy-Duty Cable Tray Manufacturer**

Maximize efficiency and reduce costs with Fire Rated Cable Trays of NewReach, it features 3-meter lengths, a 150mm laying width, and a 10kg/m load rating on a 1.65-meter span. The hanger system



### **Discover the Best Cable Tray Price: Top 5 Budget-Friendly Options**

In conclusion, whether you prioritize cost, weight, or specific environmental resistance, there is a cable tray option out there for everyone. Make your choice wisely, and enjoy the benefits of effective cable



## Cable Trays and Fire Protection Systems: Keeping

It involves understanding how Cable Trays and Fire Protection Systems work side-by-side. Cable trays hold the wires for things like power and



### How Much Do Cable Trays Cost? A 2026 Comparison

Discover the 2026 cost breakdown for cable trays compared to conduit and wire mesh. Compare material prices, labor savings, and performance

### Fire resistance cable tray

Shop high-quality fire resistance cable trays for reliable networking. Customize your solution with durable, efficient, and cost-effective options. Buy now!



### Fireproof Channel Cable Tray System

The fireproof channel cable tray system is produced by galvanized channel cable tray after processing surface treatment of a layer of fireproof coating. In addition,



## **FIRE RESISTANT PROOF CABLE TRAY, DIN STANDARD E90**

Cablofil fire resistant and fire proof cable trays are increasingly specified in the construction, power, oil, gas, petrochem, rail and utilities industries. Cablofil cable tray has been successfully tested and



## **Fire protection for cables & cable trays , Flamro**

With our fire protection for cable systems, we ensure that your lines meet the highest safety standards and are reliably protected in the event of an emergency.



## **Fire resistance**

Fire resistance E30/E60/E90 Introduction Basor Electric, sensitive to the need to minimize the consequences of a fire, has subjected its cable trays to rigorous fire resistance tests to ensure the

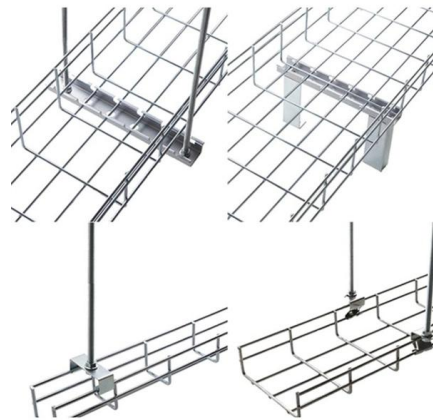

## **Basor Electric**

Resistance to fire E30/E60/E90 Introduction Basor Electric, sensitive to the need to minimize the consequences of a fire, has subjected its cable trays to rigorous fire



## Trunking and Cable Tray Protection

Fire prevention is a critical aspect of safeguarding both residential and commercial buildings. One of the essential components in this arena is the protection of



### CMU School of Computer Science

å 10 ä ,EURå fä ? 10 ä ,EURç(TM)¾ 100  
ä ,EURç(TM)¾ås 100 ä ,EURå f 1000 ä ,EURå  
fås 1000 ä ,EURâ--<ä ,EUR 101  
ä ,EURç(TM)¾é>¶ä

## Contact Us

---

For datasheets, pricing, or custom high-speed optical interconnect solutions, please visit:  
<https://www.syropy.com.pl>