

# **Grid-connected relay protection**





## Grid-connected relay protection

---



### Distributed relay protection for distribution network based on hybrid

Busbars in the distribution network may be connected with loads, distributed power supplies and feeders. Therefore, in order to protect the distribution network equipment from serious

### Basic protection relay knowledge

On the other hand, unselective protection operation in the extra high voltage network - i.e. at the national grid level- may endanger the stability of the whole power system, possibly leading to a

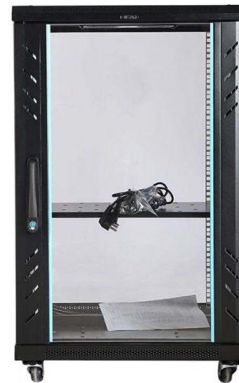

### Research on grid-connected distributed generation considering relay

2. Impact of DG on Distributed Network Relay Protection smaller than that when DG is not connected, which may cause CB2 to refuse to operate.

### Research on grid-connected distributed generation considering relay

Based on the impact analysis of the number of DGs, their locations and capacities upon short circuit currents, this paper presents an optimal DG placement method to maximize the



### **Optimal adaptive protection of smart grids using high-set**

Although different studies have been done in the field of optimal protection of smart grids, there is a research gap in developing an adaptive



### **Analysis of the Effects of Grid-Connected**

The grid-connected operation of charging/discharging stations changes the original load, power supply, and network structures of the distribution



### **Power System Protective Relays: Principles & Practices**

Protective relays and devices have been developed over 100 years ago to provide "lastline" of defense for the electrical systems. They are intended to quickly identify a fault and isolate it so the balance of





## SIPROTEC Protection Relays , Siemens

SIPROTEC: Multifunctional protection relays  
Experience the benchmark in grid protection,  
automation, and monitoring! SIPROTEC 5, built  
on



## Adaptive Protection Scheme Using Optimal Coordination of Directional

The integration of Distributed Generation (DG) in  
Grid-connected systems presents challenges in  
maintaining reliable protection schemes,  
particularly in coordin

## Advanced power grid protection

NSD570 management IAN interface accept  
"GOOSE messages" 3 according (G3IM) - secure  
remote connection to IEC 61850-8-1 from  
protection relays and monitoring with GOOSE  
interface in future.

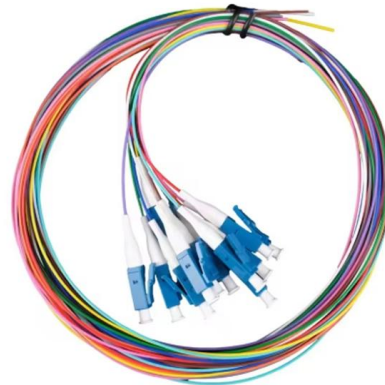

## Protective Relay: Working, Types, and Applications

Learn about protective relays, their working  
principle, types, and applications in power  
systems. Discover how relays protect  
transformers,



## Adaptive Protection Scheme Using Optimal Coordination of Directional

The integration of Distributed Generation (DG) in Grid-connected systems presents challenges in maintaining reliable protection schemes, particularly in coordinating Directional Overcurrent Relays

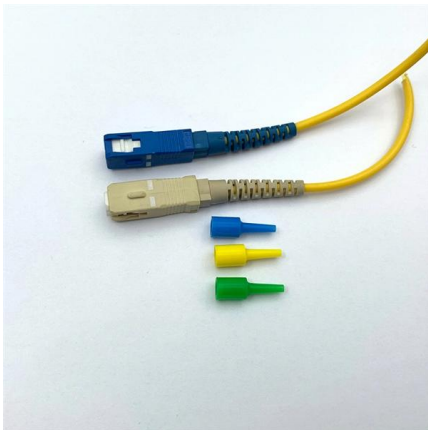

## Relay protection of the main grid and customer connections

Introduction Fingrid's application guideline for relay protection presents the operating principles of the relay protection in Fingrid's 110, 220 and 400 kV power networks and the requirements for operation

## Relay protection of the main grid and customer connections

The 110 and 220 kV lines of the main grid are protected by means of two primary protection schemes (two distance relays or a distance and a differential line relay) or a primary protection relay (distance



## Research on grid-connected distributed generation considering relay

Abstract The access of distributed generation can cause some impacts on the distribution network, especially the change of the magnitude and direction of the short-circuit current may cause the relay



## Societal and technology trend report

The crisis of traditional relay protection: A disruption of the technological paradigm Using the high short-circuit currents and system inertia provided by synchronous generators, traditional relay protection



### Relay protection for power-electronics-dominated power grids:

Recognizing the dire need for advanced relay protection, this report presents a comprehensive analysis of the evolving landscape. It outlines technical challenges, potential innovative solutions, equipment

### Intelligent protection systems for grid-connected renewables: A review

This review critically examines the role of AI in enhancing grid protection, focusing on fault detection, isolation, classification, adaptive relay coordination, islanding detection, and the mitigation

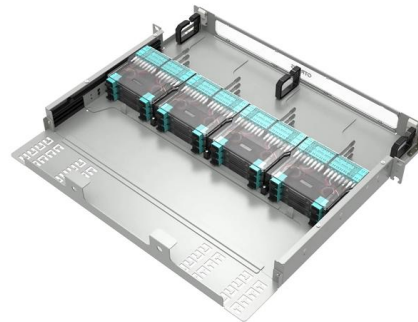

### Interconnection protection for renewable and distributed generation

ABB's interconnection protection relays have been designed to comply with today's grid codes. They continually supervise the distributed generation units and ensure they stay connected also during



### **Adaptive Overcurrent Protection Framework for Grid-Connected Multi**

This paper proposes an adaptive overcurrent protection scheme designed for a grid-connected network consisting of one main utility grid and three interconnected microgrids.

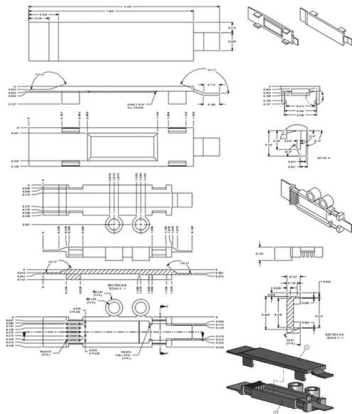

### **Optimal adaptive protection of smart grids using high-set**

Much attention has been paid to optimizing smart grids (SGs) and microgrids (MGs) protection schemes. The SGs' operation in different operating

### **Protection, Control & Metering**

GE Vernova's Protection, Control, and Metering solutions deliver precise, high-performance automation for today's evolving grid. From advanced relays to



### **A review on adaptive power system protection schemes for future**

Abstract Power system protection is crucial for maintaining the stability and reliability of the electricity grids and preventing costly disruptions. Conventional protection devices operate on pre



### **CM-UFD.M33 , ABB**

The CM-UFD.M33 is a multi-functional grid feeding monitoring relay, which provides interface protection and is to be installed between a renewable energy system



### **Societal and technology trend report**

Next, this framework is applied to two representative line-protection schemes - line distance protection and line differential protection - for quantitative evaluation under PEDG conditions.

## **Contact Us**

---

For datasheets, pricing, or custom high-speed optical interconnect solutions, please visit:  
<https://www.syropy.com.pl>