

Fiber Optic Vibration Sensor Standards





Fiber Optic Vibration Sensor Standards



Distributed Fiber-Optic Sensors for Vibration Detection

Distributed fiber-optic vibration sensing technology is able to provide fully distributed vibration information along the entire fiber link, and thus external vibration signals

High-Temperature Fiber-Optic Vibration Sensor Based on an Atomic

Request PDF , On Aug 22, 2024, Shengjie Cao and others published High-Temperature Fiber-Optic Vibration Sensor Based on an Atomic Frequency Standard , Find, read and cite all the research you

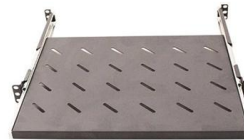

Webit Cabling

Distributed Low False Alarm Fiber Optic Vibration Perimeter System

Our fiber optic vibration sensor delivers 24/7 real-time perimeter monitoring for high-security sites (airports, borders, power plants). Using distributed sensing technology, it detects digging, climbing,



(PDF) Vibration Detection Using Optical Fiber Sensors

In this paper, the most frequently used vibration optical fiber sensors will be reviewed, classifying them by the sensing techniques and measurement



Product Catalog



News

As industrial systems shift to optical transmission, Ingiant fiber optic slip rings lead with proprietary technology, military quality, full customization, ultra-long life, and professional support.

Vibration Detection Using Optical Fiber Sensors

In this paper, the most frequently used vibration optical fiber sensors will be reviewed, classifying them by the sensing techniques and measurement

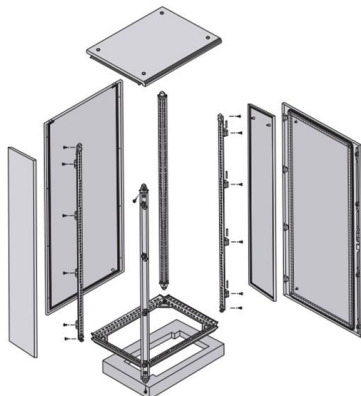

From standard 1U to 8U sizes to fully customized Non-standard enclosures.

What Are Fiber Optic Sensors and How to Choose the

What is a fiber optic sensor used for? Their applications are extensive, ranging from verifying part positioning in factories with industrial fiber

(PDF) Fiber Optic Vibration Sensors



This work presents the design and test of a fiber optic-based one-axes accelerometer. This device is a reflexive-optical accelerometer and implements a membrane for the seismic mass.



High-Temperature Fiber-Optic Vibration Sensor Based on an Atomic

ACS Photonics, volume 11, issue 9, pages 3713-3721 High-Temperature Fiber-Optic Vibration Sensor Based on an Atomic Frequency Standard Shengjie Cao 1, Jiandong Bai 1

Fiber Optics Sensors Standards Report

Standards for fiber optic sensors must encompass details related to the respective physical sensor functionality, sensor response for different measurands such as strain, temperature, or other



Fiber Optic Vibration Sensors

This fiber optic vibration sensor is a low cost and reliable, which is alternative for non-contact vibration detection with high-resolution frequency analysis. However, the multimode fiber having low



Fiber optic vibration sensor for applications in the field of ground

The sensing function principle is based on the push-pull principle of the mass-spring system of a total of three interferometers. A housing was designed and fabricated using 3D printing



5-INCH COLOR TOUCHSCREEN
Intuitive operation, easily accessible with just one touch



Industrial-grade CPU
sensitive response
1 second startup
Smooth experience

High-precision ultra-long distance distributed optical fiber vibration

Distributed optical fiber vibration sensing (DOFVS) has emerged as a vital technology for the safety monitoring of long-distance critical infrastructure, owing to its distinct advantages, including

Microphone

A subtype of fiber-optic microphone uses a Fabry-Pérot interferometer as the sensing element. In these sensors, two partially reflective mirrors form an optical cavity



Optical-fiber vibration sensor using step interferometry

Distributed fiber-optic vibration sensors receive extensive investigation and play a significant role in the sensor panorama. Optical parameters such as



What is Fiber Optic Sensing?

Distributed Temperature Sensing (DTS), Distributed Temperature and Strain Sensing (DTSS) and Distributed Acoustic Sensing (DAS) are all various types of fiber optic sensing technologies which



ODVA Fiber Optic Connectors (DLC, SC, MPO) - Rugged Waterproof

ODVA fiber optic connectors, cable assemblies & adapters - IP67 waterproof for FTTA and harsh environments. Discover key features, specs, installation tips & FAQs.

Fiber-optic Sensors - Buying Guide & Supplier List , RP

This fiber-optic sensors buying guide provides technical background, comparison of major types, selection criteria, and an overview of suppliers.

LED DISPLAY PANEL

CURRENT STATUS CLEARLY VISIBLE

IT CAN CLEARLY SHOW THE CURRENT STATUS AND VOLTAGE STATUS, WITH EFFICIENT OPERATION AND RAPID RESPONSE.

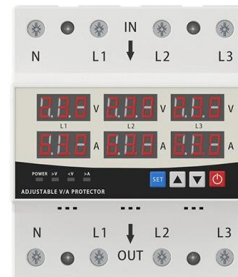

Distributed Fiber-Optic Sensors for Vibration Detection

Distributed fiber-optic vibration sensors receive extensive investigation and play a significant role in the sensor panorama. Optical parameters such as light



Fiber Optic Vibration Sensor for Environmental Monitoring

To verify the use of fiber optic vibration sensors in environmental monitoring, OKI has been conducting vibration measurement tests using existing optical fibers along railway lines and highways.



- ✓ Slow Axis Aligned (0°) - for standard sensing applications
- ✓ Fast Axis Aligned (90°) - for special modulation applications
- ✓ 45° Axis Aligned - for depolarizer applications



IEEE SA

This guide specifies the function, structure, operating conditions, technical requirements, test methods, stability analysis and packaging of fiber optic vibration sensors for public infrastructures.

Characterization of sensitivity of optical fiber cables to acoustic

A characterization of optical fibers and cables as acoustic sensors mainly for speech is probably of the greatest interest in real infrastructures, for example for the sake of security.



High-Temperature Fiber-Optic Vibration Sensor Based on an Atomic

Here, we report a high-temperature self-calibration fiber-optic vibration sensor based on an atomic frequency standard system for the first time. The absolute stability of the transition



Hamamatsu C11482GA TG-Series Miniature Fiber Optic Spectrometer

Overview The Hamamatsu C11482GA TG-Series Miniature Fiber Optic Spectrometer is a compact, OEM-optimized near-infrared (NIR) spectrometer engineered for high-fidelity spectral acquisition in



Optical Fiber Vibration Sensors

Optical fiber sensors were embedded along a high-security perimeter to detect unauthorized movement. Unlike traditional systems, these sensors were undetectable, had zero EMI interference, and

Distributed Fiber Optic Vibration Sensing (DVS) System

Distributed Fiber Optic Vibration Sensing (DVS) is an advanced optical sensing technology that uses single-mode optical fiber (SMF, G652 recommended) as



Rugged Fiber Optic Connector Selection Guide

Rugged Fiber Optic Connector: Selection Guide for Harsh Environments Fiber optic networks deployed in industrial facilities, military installations, offshore platforms, and transportation



Fiber Optic Sensor TP

Durable ABS and Metal Construction: The fiber optic probe sensor cable combines high-strength ABS plastic with metal components for enhanced structural integrity. It withstands mechanical stress,



Contact Us

For datasheets, pricing, or custom high-speed optical interconnect solutions, please visit:

<https://www.syropy.com.pl>