

# **Effect distance of multimode 10 Gigabit fiber optic cable**





## Overview

---

For 10 Gigabit Ethernet over OM2 fiber, the typical reach is up to 82 meters (approximately 269 feet). This reach is based on the standard OM2 fiber characteristics and the use of 850nm wavelength transceivers, which are common for multimode fiber applications. The implementation of a cabling design, compatible with LED and laser-based Ethernet network devices, which will allow the integration. However, the dispersion-compensating fibers can support more than 200 kilometers. OM3, OM4, and OM5 are types of multimode optical fibres commonly used in data centres and enterprise environments to support various network speeds and transmission distances, including 10 gigabit Ethernet (10G), 40 gigabit Ethernet (40G), 100 gigabit Ethernet (100G) and 400 gigabit Ethernet.



## Effect distance of multimode 10 Gigabit fiber optic cable

---



### Fiber Optic Cable Distance: A Comprehensive Guide

Learn all about fiber optic cable distance and the key factors that affect it. Find out how to select the appropriate cables for your network and

### How Far Can Multimode Fiber Optic Cables Transmit?

This article explores the transmission distance limitations of multimode fibers across different transmission speeds, analyzes the key factors



### OM2, OM3, OM4 vs. OM5 , How to Choose the Right

OM stands for Optical Multimode. The larger core in multimode fiber allows several light paths, or modes, to travel at once. That design makes the fiber optic patch



### Cisco 10GBASE SFP+ Modules Data Sheet

The Cisco 10GBASE SFP+ modules give you a wide variety of 10 Gigabit Ethernet connectivity options for data center, enterprise wiring closet, and



### Optic Modules Datasheet

Optic Modules Data Sheet SFP (form factor) = small form-factor pluggable transceiver SMF (media) = single-mode fiber-optic MMF (media) = multimode fiber-optic XFP (form factor) = 10-gigabit small



### OM3 Multimode Fiber Cable: The Ultimate Guide for 10G Networks

The OM3 fiber optic cables are used for high-speed data transfer over short to medium distances. The 50 micrometer must be optimized for laser transmission and usually uses a VCSEL



### How far can OM2 10G reach?

For 10 Gigabit Ethernet over OM2 fiber, the typical reach is up to 82 meters (approximately 269 feet). This reach is based on the standard OM2 fiber



### TN\_OM3, OM4, OM5 Distance and Speeds

OM3 is multimode 50/125 fibre that supports 10G Ethernet over a pair of fibres at distances of up to 300 metres, making it suitable for shorter-range applications within data centres and enterprise networks.



### 10 Gigabit Ethernet

10 Gigabit Ethernet (10GE, 10GbE, or 10 GigE) is a group of computer networking technologies for transmitting Ethernet frames at a rate of 10 gigabits per second.

### Cisco 40GBASE QSFP Modules Data Sheet

Cisco QSFP-40G-CSR4 Cisco 40GBASE-CSR4 QSFP Modules extend the reach of the IEEE 40GBASE-SR4 interface to 300 and 400 meters on laser-optimized OM3, and OM4/OM5

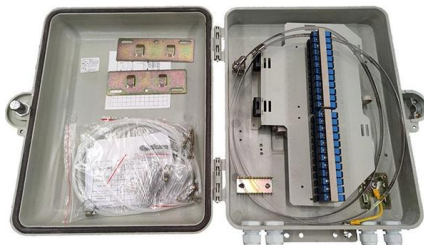

### Small Form-factor Pluggable

Small Form-factor Pluggable Small Form-factor Pluggable connected to a pair of fiber-optic cables Small Form-factor Pluggable (SFP) is a compact, hot-pluggable



## Fiber Optic Cables vs. Ethernet Cables: What's the

Fiber optic cables and Ethernet cables are two of the most important data transfer cable standards there are, but with their use cases often crossing



## Singlemode vs Multimode Fiber Optic Cable

We breakdown the differences between single mode and multimode fiber optic cable, covering aspects like physical structure, bandwidth over

## Fiber-optic communication

An optical fiber patching cabinet. The yellow cables are single-mode fibers; the orange and blue cables are multi-mode fibers: 62.5/125 um OM1 and 50/125 um



## Understanding the Distance Limitations of Multimode

Understanding the distance limitations of multimode fiber is crucial for ensuring that your data center network can meet the performance and scalability



## Fiber Optic Cable Range: Comprehensive Guide

Fiber optic cable range varies depending on whether you're using single or multimode fiber. Learn the potential for both cable types.



MTP MPO SC-Type Fiber Adapter



### StarTech Cisco SFP-10G-LRM Compatible SFP+ Transceiver

The SFP10GLRMST is a Cisco SFP-10G-LRM compatible fiber transceiver module that has been designed, programmed and tested to work with Cisco(TM) brand switches and routers. It delivers

### Search results for: Madagascar Fiber Optic Cable Fiber Optic

Madagascar Fiber Optic Cable Fiber Optic Transmitters, Receivers, Transceivers Products (83) Images Newest Products Results: 83



### What is the maximum 10g multimode fiber distance?

These fibers are designed to reduce attenuation and dispersion, which helps to increase the maximum distance over which 10G data can be transmitted. The maximum distance for 10 Gbps data transfer



## Global fiber Optic cable market analysis research report

3. Bandwidth limitations of multimode fiber: In data center applications, the bandwidth restrictions of multimode fiber have become a key

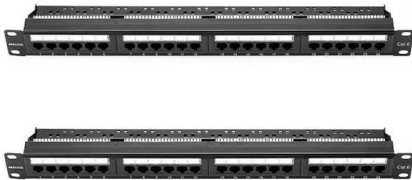

### 10 Gigabit Ethernet Fiber Design Considerations

This paper has introduced some basic fiber related concepts and outlined some of the key points to understand and consider when designing a 10 Gigabit Ethernet network.

### Understanding Distance Limits with Multimode Fiber

OM3 and OM4 came after the 1000BASE-SX standard was written, so the distances up to 860 meters listed in the chart below are based on the



### All Things Fiber Optic Internet Cables

Discover the different types of fiber optic cables and the benefits of fiber optic internet. Compare fiber connections with other types of home internet.



## Multimode vs Single Mode Fiber Patch Cords: Which

Fiber optic patch cabling is part of a fiber optic network construction, so the important choice is whether to use multimode patch cords or single mode



## Exploring Multimode Fiber Distance Limits in Data Centers

Explore multimode fiber distance limits in data centers, including fiber types, performance, and solutions like WDM technology to extend range and



## What Is Fiber Optics? Definition from



## All Kinds of Fiber Optic Patch Cords - SC, LC, FC, ST

Learn about SC, LC, FC, and ST fiber optic patch cords, their uses in FTTH, telecom, and data centers, and how to choose the right type.

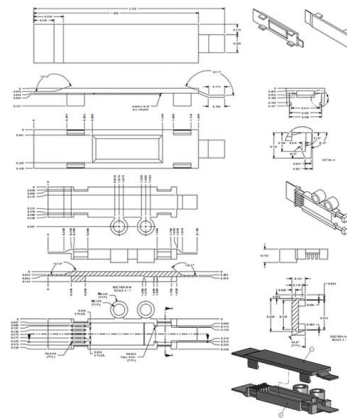

## Fiber Optic Patch Cable Directory

10 Gigabit 50µm OM3 Patch Cable Multimode fiber networks are best suited for use in applications such as LAN and campus installations. Short distance data transmission and audio visual applications



## SearchNetworking

Fiber optic cables are commonly used because of their advantages over copper cables. Some of those benefits include higher bandwidth and



## Contact Us

---

For datasheets, pricing, or custom high-speed optical interconnect solutions, please visit:  
<https://www.syropy.com.pl>