

Causes of Bit Errors in Fiber Optic Communication





Causes of Bit Errors in Fiber Optic Communication



A Review on Optimization of Bit Error Rate and Q-factor in Fiber Optic

Bit Error Rate (BER) is an indication of how often data has to be retransmitted because of an error. The different modulation techniques scheme is proposed for improvement of BER in fiber optic

Bit Error Rate (BER) in Optical Links: Causes and Mitigation

Bit Error Rate is a fundamental consideration in the design and operation of optical communication systems. By understanding the causes of bit errors and implementing effective

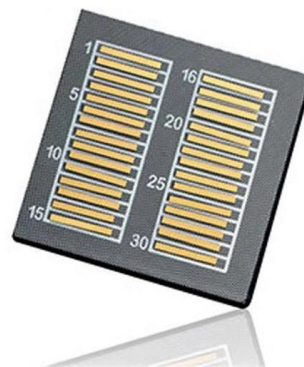

Common Causes of High Bit Error Rates and Packet

This article analyzes why bit errors and packet loss occur in optical links, covering physical and network layer issues as well as security risks, and provides a step

Bit Error Rate - tester, BERT, data transmission

What causes bit errors in optical data transmission? In optical systems, bit errors are often caused by noise in receivers and amplifiers, optical losses, signal distortion



Bit Error Rate Optimization in Fiber Optic Communications

International Journal of Machine Learning and Computing, Vol. 1, No. 5, December 2011 Bit Error Rate Optimization in Fiber Optic Communications S.



Bit Error Rate Optimization in Fiber Optic Communication

V. OPTICAL FIBER An optical fiber is a thin and transparent fiber which acts as a waveguide, or light pipe, to transmit light from one point to other. Optical fibers are mostly used in fiber optic



The Importance of Bit Error Rate Testing to Fiber Optic Channels

Fundamentally for fiber optic systems, bit errors mainly result from imperfections in the components used for the link, but can also result from optical fiber dispersion and attenuation or any noise or



Bit Error Rate Optimization in Fiber Optic



Communications

dual bit. Bit error is totally dependable on signal loss. To find out the bit error in optical fiber the practical works is accomplished in Link3 to observe the signal loss in fiber optics communication. Optical Time

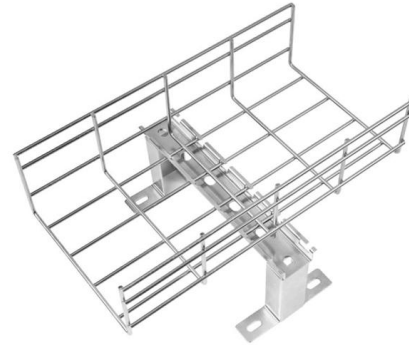

Bit Error Rate Optimization in Fiber Optic Communications

Bit Rate Maximizing by Optimizing Repeater Spacing Product for Optical Communication Systems Article Full-text available Jul 2021

Bit Error Rate Testing (BERT)

Optical fiber delivers the high bandwidth, low latency, reach, and flexibility required to meet the demands of developing applications, like next-gen Wi-Fi, high-availability A/V, and 5G within a single building



Improvement of Bit Error Rate in Fiber Optic

The signal power amplitude is tested for both optical fiber and PIN photodetector optical time-domain visualizer and RF spectrum analyzer by using



Bit Error Rate Optimization in Fiber Optic Communications

Abstract--In telecommunication, the Bit Error Rate (BER) is an indication of how often data has to be retransmitted because of an error. The

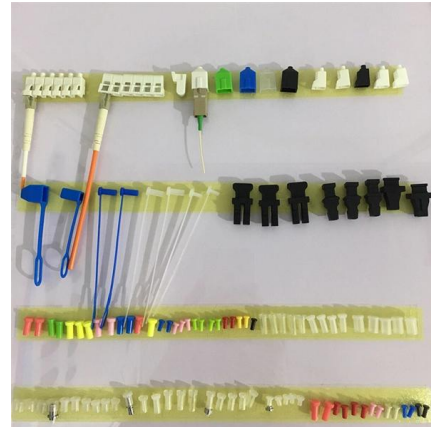

Bit Error Rate Performance for Optical Fiber System

The concept is to use carrier wave communication . Fiber optics have become a huge building blocks in the telecommunication field and it's the best system for transmitting information, since its invention

Understanding FEC and Its Implementation in Cisco Optics

To meet the skyrocketing bandwidth demand, the optical networking industry has pushed data rates to 100 Gbps and beyond. Optical transmission is



Optimization of Bit Error Rate and Q-factor in Fiber Optic

Hence multiple sections of constant dispersion single-mode fiber and dispersion-compensating elements whose lengths and group velocity dispersion are chosen to optimize the overall transmission



(PDF) Practical Bit Error Rate Measurements on Fibre

In this paper we describe the principles and design of a fibre optic communications teaching package and a cost effective extension module to this



Bit Error Rate Optimization in Fiber Optic Communications

I. INTRODUCTION Optical fibers are widely used in fiber optic communications which permits transmission over longer distances and at higher bandwidths than other forms of communication.

AN1047 Understanding bit-error-rate Hotlink

One of the largest causes of random or noise-induced errors is the optical receiver. Here light received from the fiber is converted to an electrical signal through a transimpedance amplifier.

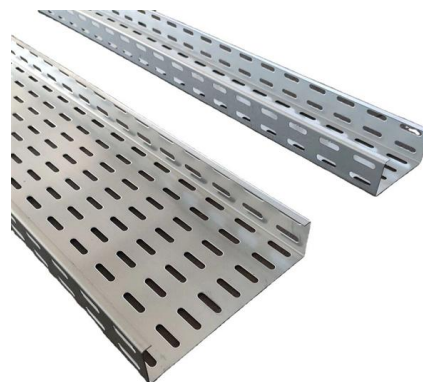

Evaluation of Bit Error Rate probability for radio communications and

The present paper concerns the estimation of BER parameter (Bit Error Rate) for radio systems and FOCS (fiber-optic communication systems), taking into consider



Bit Error Rate Optimization in Fiber Optic Communications

The BER may be improved by choosing a strong Optical fibers are widely used in fiber optic signal strength (unless this causes cross-talk and more

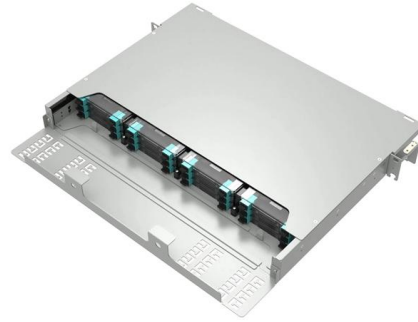

Beginners Guide to Fiber Optic Bit Error Ratio (BER) Measurement

Bit error ratio (BER) measurement is the fundamental measurement of the quality of the fiber optic communication system. It measures the system's probability that transmitted bits will be correctly

Understanding Bit Error Rate in Optical Communications

This comprehensive guide will explore the causes of Bit Error Rate in optical communications, methods for measuring and optimizing BER, and its impact on network performance.



Improvement of Bit Error Rate in Fiber Optic Communications

Abstract--The bit error rate (BER) is the percentage of bits that have errors relative to the total number of bits received in a transmission. The different modulation techniques scheme is suggested for



Contact Us

For datasheets, pricing, or custom high-speed optical interconnect solutions, please visit:

<https://www.syropy.com.pl>