

Attenuation of wavelength division multiplexer





Overview

This technique enables bidirectional communications over a single strand of fiber (also called wavelength-division duplexing) as well as multiplication of capacity.



Dense Wavelength Division Multiplexing

5.1.1 Coarse wavelength-division multiplexing and dense wavelength-division multiplexing
Wavelength-division multiplexing (WDM) enables multiple-shift usage of transmission fibers by transmitting a

Wavelength Division Multiplexers (WDM)

Wavelength Division Multiplexing (WDM) is a technique in fiber-optic communication systems that enables multiple optical signals with different wavelengths to be combined, transmitted, and



Parallel wavelength-division-multiplexed signal transmission and

Here we propose a scalable on-chip parallel IM-DD data transmission system enabled by a single-soliton Kerr microcomb and a reconfigurable microring resonator-based CD compensator.



(PDF) Turbidity-tolerant underwater wireless optical

Turbidity-tolerant underwater wireless optical communications using dense blue-green wavelength division multiplexing



16-channel dual-tuning wavelength division

In this paper, a 16-channel SOI-based wavelength division multiplexer/demultiplexer with dual-tunable function is demonstrated, which can realize the wavelength

Buy Wavelength-Division Multiplexing (WDM) , Best wholesale

Get price quotes for Wavelength-Division Multiplexing (WDM). Search, find, compare and shop for Wavelength-Division Multiplexing (WDM) on FindLight. Contact suppliers directly with one click.



WDM and Fiber Attenuation in FTTx Systems Explained

Learn how wavelength division multiplexing (WDM) affects fiber attenuation in FTTx systems and what are its benefits and drawbacks.



High-power wavelength division multiplexer

High-power wavelength division multiplexer is a device that combines two or more optical carrier signals of different wavelengths (carrying various information) at the transmitting end using a multiplexer

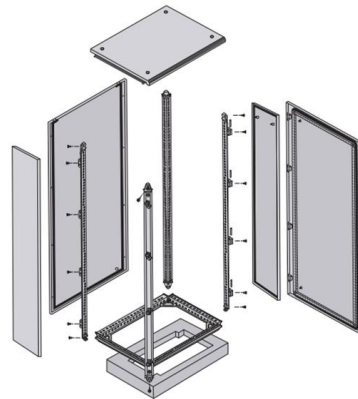

Research on Optimization and Application of Wavelength Division

This paper discusses in detail the wavelength division multiplexing (WDM) technology, which effectively increases the communication capacity and transmission sp

Wavelength Division Multiplexing

Wavelength division multiplexing (WDM) is a technology for increasing the transmission capacity of optical fiber communications by sending multiple data

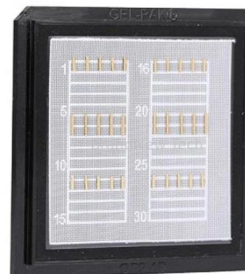

Wavelength Division Multiplexing

Wavelength division multiplexing is a multiplexing technique working in the wavelength domain. It is commonly used in the area of optical fiber communications.

Wavelength Division Multiplexing



Wavelength division multiplexing (WDM) has enabled a revolution in communications technology. This article describes the technology, critical components of WDM systems, and transmission impairment

MORE CASES PRESENTATIONS



Introduction To WDM

This introductory chapter of Wavelength Division Multiplexing: A Practical Engineering Guide traces the history of wavelength division multiplexing (WDM). WDM refers to a multiplexing and transmission

25G/50G PON Coexistence in FTTx: Link Budget & Architecture

Introducing a Wavelength Division Multiplexer Coexistence Element (WDM-r) fundamentally degrades the available optical power budget across the distribution network. This passive insertion



What is Wavelength Division Multiplexing (WDM): A

Wavelength Division Multiplexing (WDM) stands out as a cornerstone, enabling multiple data streams to travel simultaneously over a single fiber. This



Wavelength Division Multiplexing (WDM) , Springer Nature Link

Wavelength division multiplexing or WDM allows the combining of a number of independent information-carrying wavelengths onto the same fiber, because of the wide spectral



Cisco ONS 15454 DWDM Engineering and Planning

Wave division multiplexing (WDM) maps multiple optical signals to individual wavelengths and multiplexes the wavelengths over a single fiber.

Research on Optimization and Application of Wavelength Division

This paper discusses in detail the wavelength division multiplexing (WDM) technology, which effectively increases the communication capacity and transmission speed by simultaneously transmitting



Wavelength Division Multiplexing

Concept and Process of Wavelength Division Multiplexing In WDM, the optical signals from different sources or (transponders) are combined by a multiplexer,



Wavelength Division Multiplexing (WDM)

Wavelength Division Multiplexing (WDM) Optical signals of different wavelength (1300-1600 nm) can propagate without interfering with each other. The scheme of

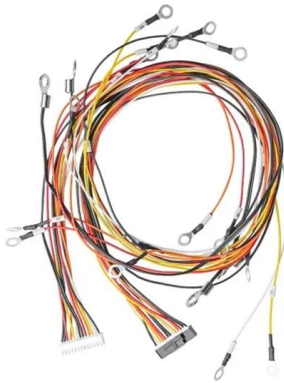

WAVELENGTH-DIVISION MULTIPLEXING OPTICAL NETWORKS

Whereas in the first optical communications networks, light was transmitted through the fiber using a single wavelength, WDM permits light at multiple, different wavelengths, to be transmitted through a

Wavelength Division Multiplexing Introduction Guide

Due to the attenuation in the fiber the quality of the DWDM signal constantly decreases and when it is amplified the noise is also amplified. This introduces limits for how many times it is possible to



3.5 Wavelength multiplexing and demultiplexing

3.5 Wavelength multiplexing and demultiplexing Wavelength multiplexers and demultiplexers are needed in order to be able to use wavelength division multiplexing. With just two wavelengths, the



Wavelength-Division Multiplexing

Wavelength Division Multiplexing (WDM) is defined as an approach that multiplexes multiple wavelength channels from different end-users into a single fiber, facilitating the transmission of various services



Optically Multiplexed Systems: Wavelength Division

This ushered in the need of multiplexers, specifically wavelength division multiplexers. A few popular optical multiplexing techniques are discussed

Contact Us

For datasheets, pricing, or custom high-speed optical interconnect solutions, please visit:
<https://www.syropy.com.pl>