

Absorption-type fiber optic temperature sensor





Absorption-type fiber optic temperature sensor



Fiber Optic Sensors: Types, Working Principle

Explore fiber optic sensors: their working principles, types (intrinsic, extrinsic, hybrid), and diverse applications in mechanical, chemical, and structural health monitoring.

Semiconductor absorption fiber-optic temperature sensor

A novel semiconductor absorption fiber-optic temperature sensor was developed for electrical power system. The sensor is based on the temperature dependence of the band edge



High sensitivity fiber optic temperature sensor composed of two

A high-sensitivity fiber optic temperature sensor based on the enhanced harmonic Vernier effect (HVE) is proposed, which consists of two Fabry-Perot interferometers (FPI) that are

FOTEMP TS Series Fiber Optic Temperature Probes

High precision FOTEMP TS fiber optic temperature probes are for operating environments where conventional electronic-based temperature sensors,

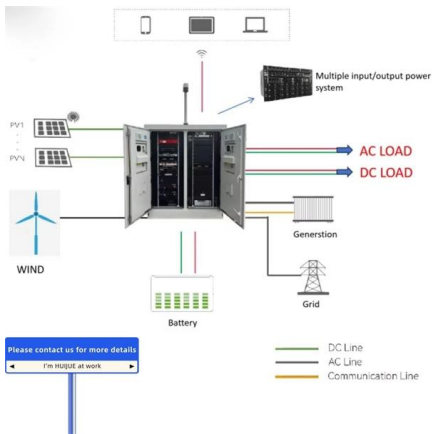

National Center for Biotechnology Information

Hier sollte eine Beschreibung angezeigt werden, diese Seite lässt dies jedoch nicht zu.

Fiber optic sensors

Our fiber optic sensors use a Gallium Arsenide (GaAs) crystal at the fiber tip, making them ideal for highly accurate temperature measurements in environments



What Are Fiber Optic Temperature Sensors and How Do

Cost Fiber optic temperature sensors tend to be more expensive than traditional temperature sensors, primarily due to the cost of the optical fiber and

Fiber Optic Sensors & Transducers its Types and



Fiber Optic Sensor Fiber optic sensors are a modern innovation in the field of sensing and monitoring. They are built on principles in which changes in



A fiber optic-film temperature sensor taking advantage of thermal

We develop a sensor model for an optical fiber-germanium (Ge) film type temperature sensor based on the modified optical film theory, which involves temperature-dependent absorption below infrared



Fiber-optic temperature sensor based on interaction of temperature

During the development of a reflective-type fiber-GaAs-platelet absorption temperature sensor , we found a very strong temperature-dependent re-reflection change on the fiber-semiconductor



Semiconductor Absorption Fiber-optic Temperature Sensor

A novel design for fiber-optical temperature sensor based on the property of semiconductor band edge absorption used under adverse conditions. The influence of light source intensity fluctuation, and the





Fiber Optic Temperature Sensors for High-Voltage Monitoring

Our temperature sensors are designed with Gallium Arsenide (GaAs) crystals as their fiber tip. They measure temperature fluctuations through shifts in their absorption spectrum. As the temperature



Preparation and Performance of a Fiber Optic Temperature Sensor

The tip of a piece of plastic fiber was dyed with thymol blue to form a temperature probe. The fiber optic sensor was calibrated on a heatboard by comparison with a K-type thermal couple.

FOTEMP TS Series Fiber Optic Temperature Probes

Micronor Sensors offers a complete range of fiber optic temperature sensors, probes and interfaces for high precision temperature measurement in challenging

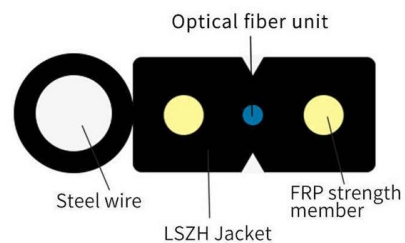

Fiber Optic Temperature Sensors: Operation

Find out more about fiber optic temperature sensors, their principle of operation & how they are applied in industrial temperature measurement.



Fiber Optic Temperature Sensing and Measurement , Luna

High-definition temperature sensing based on the natural Rayleigh backscatter in optical fiber delivers a virtually continuous line of temperature measurements with



Optical Fiber Sensors for High-Temperature Monitoring:

This paper will review the development of fiber-optic high-temperature sensors over the last 30 years, presenting their design and fabrication methods according to



Optical Fiber Based Temperature Sensors: A Review

In this article, we have reviewed several optical fiber-based temperature sensors reported in recent decades, including their design, fabrication, sensing materials, and performance.



Fiber-optic semiconductor absorption temperature sensor for electrical

A method of referencing in an extrinsic optical fiber sensor system utilizing temperature dependence of the absorption edge in a semiconductor crystal (semi-insulating iron-doped indium





CHAPTER 09 FIBER OPTIC SENSORS

EXTRINSIC FIBER OPTIC SENSORS: In such type of sensors, sensing takes place in a region outside of the fiber and essentially fiber serves as a conduit for the to and fro transmission of light to the



Temperature Measurement Using Optical Fiber

The paper deals with the overview of fiber optic methods suitable for temperature measurement and monitoring. The aim is to evaluate the current

Linearity analysis of fiber-optic temperature sensor

During the development of a reflective-type fiber-GaAs-platelet absorption temperature sensor , we found a very strong temperature



OTG-A Fiber optic temperature sensor

The OTG-A is made with industry standard optical fiber and is compatible with all the GaAs (SCBG) signal conditioners. This compact and robust fiber optic temperature sensor is available with different



(PDF) Fiber Optic Temperature Sensors

The physical phenomenon and construction of optic fiber sensors are discussed in this paper. The description is limited to those sensors that are



What Are Fiber Optic Temperature Sensors and How Do

With fiber optic temperature sensors, multiple sensors can be integrated into a single fiber strand, allowing for the monitoring of temperature at

Fiber Optic Sensor : Types, Working, Interfacing & Its

Fiber-optic sensors are resistant to electromagnetic interference & they do not conduct electricity thus they are applicable in some locations where



Fiber Optic Temperature Sensors

To date, various types of fiber optic temperature sensors have been reported in the literatures and they are mostly based on fiber interferometric [Choi et al., 2008] and fiber Bragg grating (FBG) [Han et al.,



Fiber optic evanescent wave absorption-based sensors: A detailed

Intrinsic fiber optic sensors were further categorized based on EW absorption and fluorescence. A detailed review of EW based sensing techniques with different organic and inorganic



In-Depth Overview of Fiber Optic Temperature Sensors

Unlike traditional electrical temperature sensors (e.g., thermocouples, RTDs), fiber optic sensors offer significant advantages such as immunity to electromagnetic

Contact Us

For datasheets, pricing, or custom high-speed optical interconnect solutions, please visit:
<https://www.syropy.com.pl>