

500kWh integrated wiring cabinet for distribution network automation





500kWh integrated wiring cabinet for distribution network automa



Distribution electric cabinet, Distribution electrical

Find your distribution electric cabinet easily amongst the 88 products from the leading brands (RITTAL, Edit Elektronik, Safybox,) on DirectIndustry, the

Elsta Mosdorfer

The cabinet systems and connection-ready distribution cabinets from ELSTA Mosdorfer form the perfect foundation for standard-compliant and safe operation



Electrical installation solutions for buildings ABB i-bus® KN

The ABB IP switches are two industrial-grade, 8 Ports, Fast Ethernet, unmanaged switches (with and without PoE) designed for installation in electrical distribution boards and easy mounting on DIN-Rails.



Power Distribution Unit

For power distribution requirements of medium to large data centers, Delta's Power Distribution Unit (PDU) is an optimal solution. The space-saving PDU is easy to



Smart power distribution solutions

Integrated automation solutions for cable networks ABB has a wide portfolio of smart power distribution solutions, that can be integrated into secondary switchgears, as well as complete compact



Guide to PLC Cabinets: Types, Layout, Wiring

Learn the essentials of designing and wiring PLC control cabinets, including component selection, cooling, wiring tips, and safety standards.



Engineered flexibility for secondary distribution , Hitachi Energy

SDA500 cabinet The RTU-based SDA500 Smart Control Cabinet provides the full bandwidth of secondary distribution system functionality in an off-the-shelf solution. It is a standardized, pre



500kWh power supply cabinet for network server rooms

Cabinet Energy Storage System 100kwh to 500kwh Floor Power Distribution Systems: Various high-performance distribution boxes, distribution cabinets, and switchgear, meeting the needs at all levels

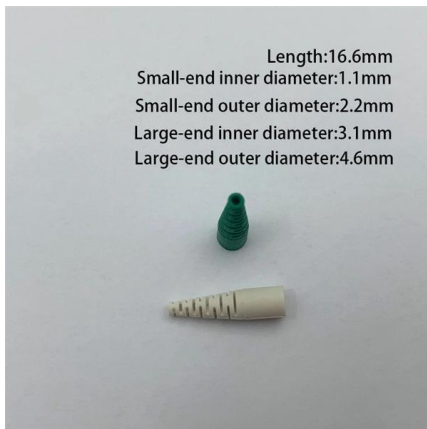

250kW/500kWh Outdoor Cabinet Energy

Efficient Cooling It adopts door-mounted embedded integrated air conditioning, which does not occupy cabinet space, improves the available space of outdoor cabinets, has better structural

PowerMonitor Products Application Guide

Virtual wiring correction capability Sag/swell detection alert Up to 20 setpoints with conditional, logical, and relational programming Single cycle metering This power meter is a scalable solution which you



ABB i-bus KNX

Sustainable Innovation for a Smart Future. The ABB i-bus® KNX is a cutting-edge smart home and building automation system, built on the globally



Electrical Cabinet Design

With advanced busbar handling and cabinet visualization in 3D and 2D, E3.series enables engineers to design control cabinets, panels, and wiring systems. It



Volga Reduces Control Panel Wiring Time by 66%

Learn more about how Volga reduced control panel wiring time by using Rockwell Automation's newly released EtherNet/IP(TM) In-cabinet Solution.

Engineered flexibility for secondary distribution , Hitachi Energy

The RTU-based SDA500 Smart Control Cabinet provides the full bandwidth of secondary distribution system functionality in an off-the-shelf solution. It is a standardized, pre-engineered, and cost



Product Catalog



Electric cabinet, Network cabinet

EED free standing panels are modular type cabinets designed for all kinds of electrical distribution and automation applications. Since the carrier frame is



Guide to PLC Cabinets: Types, Layout, Wiring

This guide will walk you through the essential steps to design and wire an efficient PLC control cabinet. We'll cover key topics like selecting components,

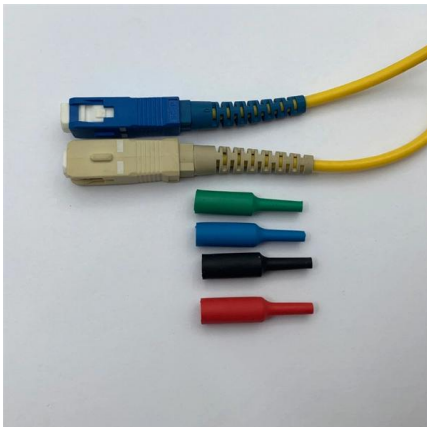

500KWh Cabinet

Enclosure: Industrial-grade outdoor/indoor cabinet Applications Peak shaving and load shifting Demand charge optimization Industrial backup power Solar + storage integration EV charging infrastructure

Distribution Coatings VARIABLE SPEED DRIVE

Endless possibilities With modern design, the variable speed drive CFW500 is a high performance VSD for applications that require speed and torque control of three-phase induction motors. The



Control cabinets, electrical cabinets and automation

We stock standard control cabinets for direct delivery and design control cabinets customized to process and specifications. All control cabinets are carefully

PRODUCT LINE PRODUCT LINE W



PRODUCTIVITY Quality and competitive edge meet when it is possible to combine efficiency and speed in the processes. Learn about WEG solutions from the automation line and have the best results



SDN Integrated Wiring Cabinet , TrizN inc

An Integrated Wiring Cabinet consolidates various wiring systems in a building--including communications, networks, telephony, video, control systems, and security--into a single hub,

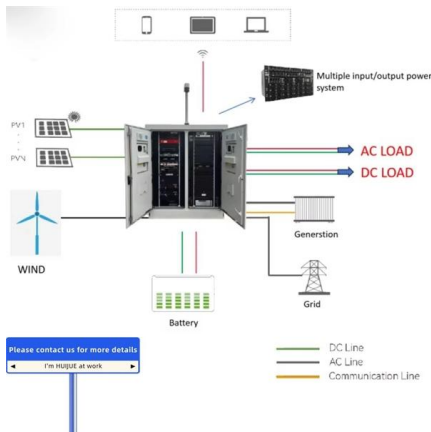

Product Drawings & Wiring Diagrams , Rockwell

Product drawing tools to help you design & apply our products. Available on-line or for download, our tools help you access information while in the office or on the go.



Structured Media Centers , Leviton Connected Home

Leviton offers a wide variety of Structured Media Centers that provide a convenient termination location for home wiring. It provides a distribution point for voice, data,





Planning of Electric Power Distribution

This comprises software tools and support for planning and configuring as well as a perfectly harmonized, complete portfolio of products and systems for integrated power distribution, ranging

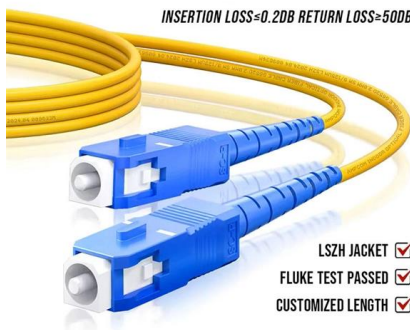

Distribution Automation Handbook

3.14 Primary Distribution Substations A primary distribution substation is the connection point of a distribution system to a transmission or a sub-transmission network. Outgoing feeders from a

DISTRIBUTED AUTOMATION FROM THE CONTROL CABINET

Terminal blocks with integrated I/O redundancy - without external components or additional wiring - simplify implementation of the redundancy concept in a sustainable way. A special role is played by



Automated Control Cabinet Wiring Solution for Scalable

Interest in automation is high, and several years of research have produced promising approaches for automated control cabinet wiring . Nonetheless, there is still no turnkey and



Distribution cabinets and panelboards

The low voltage panel boards are installed downstream the MV/LV transformers in underground substations. They ensure the global switching ON/OFF under full



500kWh power supply cabinet for network server rooms

Power Distribution Systems: Various high-performance distribution boxes, distribution cabinets, and switchgear, meeting the needs at all levels from end users to main distribution rooms.

Contact Us

For datasheets, pricing, or custom high-speed optical interconnect solutions, please visit:
<https://www.syropy.com.pl>