

3D Fiber Optic Sensor





Overview

Direct femtosecond laser based processing of Bragg gratings into the core and the cladding of an optical fiber makes it possible using just a single standard one core optical fiber for 3D shape monitoring with the advantage of no need for additional optics, the high. Fiber Bragg Grating (FBG) sensors inscribed in multi-core optical fibers have been democratized over the years and nowadays offer a compact and robust platform for shape reconstruction. In this work, we propose a novel, computationally efficient method for determining the 3D tip position of a bent. Fiber optic shape sensing has an outstanding capability to sense curvature and shape in 2D and 3D. The technology will enable cutting-edge applications in the fields of robotic and standard minimally invasive surgery – such as real-time position tracking, instrument and catheter navigation, force.



3D Fiber Optic Sensor



Fiber Optic Sensors

Fiber optic photoelectric sensors offer remote sensing/mounting options for long-distance or low- or no-power endpoint applications. Installations can be



Optimization of Fiber-Optic Sensor Parameters to Improve

Accurate deformation measurement is essential in modern engineering because structural reliability depends on precise conversion of mechanical strain into optical signals. Its performance is

FU-96 Fiber-optic sensor for liquid level detection

FU-96 Fiber-optic sensor for liquid level detection : Amazon .uk: Business, Industry & Science Customer Reviews, including Product Star Ratings, help customers to learn more about the product



FU-93 Fiber Optic Sensor

Product description Sensor FU-93 Fiber Optic Sensor Report an issue with this product or seller

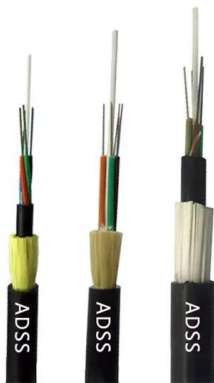
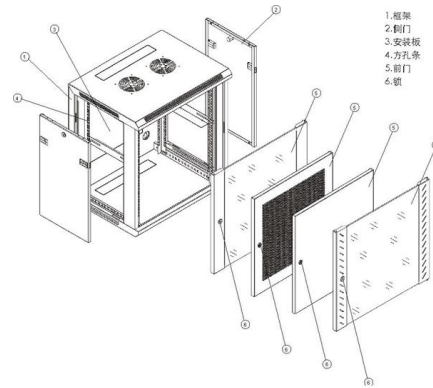

Turning Fiber into a Sensing System: The Magic of Fiber

Imagine a world where the Internet doesn't just connect but senses--detecting earthquakes, monitoring battery health, or safeguarding

The Potential of Fiber Optic Technology in Automotive

Both glass and plastic optical fibers are recyclable, providing a greener alternative to traditional wiring materials. Fiber optic technology not only meets

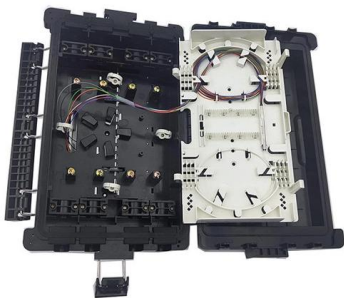
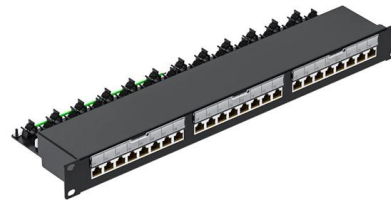

3D fiber optical shape and motion sensing

Fraunhofer Heinrich Hertz Institute Fiber Optical Sensor Systems Schematic of the femtosecond laser process for a 3D sensor fiber with cladding waveguides and fiber Bragg gratings within them

Rapid and Accurate Shape-Sensing Method Using a



In this work, we propose a novel, computationally efficient method for determining the 3D tip position of a bent multi-core FBG-based optical fiber using

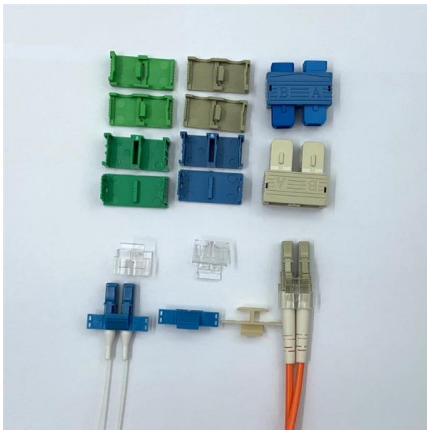

Search

Buy yl236+fiber+optic+sensor products, get a variety of yl236+fiber+optic+sensor projects and yl236+fiber+optic+sensor tutorials from DFRobot.

Home , Fiber SenSys Inc.

Fiber SenSys®, Inc., (FSI) is the market-leading manufacturer of fiber-optic intrusion detection systems for outdoor perimeters and physical data networks. FSI



Soft and Highly-Integrated Optical Fiber Bending Sensors for

This study aims to apply fused filament fabrication (FFF) 3D printing, a cheap and widely accessible technology, to implement an optical sensing solution that is both distributed and highly



Fiber Optic Sensors: Fundamentals, Principles & Applications

Extrinsic Fiber Optic Sensors Fiber is Only an Information Carrier To and From a Black Box Light Signal Generation in Black Box Depending on the Arriving Information



RS PRO 2522100 Plastic Fiber Optic Sensor 150mm/500mm/2000mm

RS PRO USB 2.0 A to Micro USB B Cable, 1mThe RS PRO USB 2.0 (Universal Serial Bus) cable is designed to provide a reliable connection between a range of devices including laptops and

High-Accuracy 3D Shape Sensor Based on Anti-Twist Packaged

Improving the accuracy of shape sensors based on multicore fibers (MCFs) is challenging but of great importance for real-time 3D shape detection, especially in visually inaccessible areas.

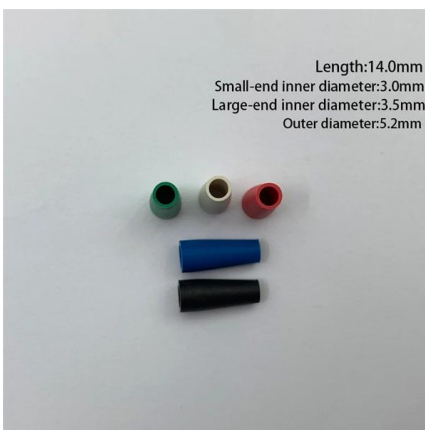

Length:14.0mm
Small-end inner diameter:3.0mm
Large-end inner diameter:3.5mm
Outer diameter:5.2mm

Fiber Optic Shape Sensors: A comprehensive review

Fiber Optic Shape Sensing is an innovative Optical Fiber Sensing Technology that uses a fiber optic cable to continuously track the 3D shape and position of a dynamic object (with unknown



Fiber Optics Sensor Market

The Fiber Optics Sensor Market, valued at USD 3.33 Trillion in 2025, is projected to reach USD 4.89 Trillion by 2030, growing at a 7.9% CAGR.



Learning to sense three-dimensional shape deformation of a single

We demonstrate proof-of-concept 3D multi-point deformation sensing via a single multimode fiber by using k -nearest neighbor (KNN) machine learning algorithm, and achieve a

Banner Engineering QS18VN6FPQ5 Photoelectric Sensor, Plastic Fiber

Replaces hundreds of other sensors Meets IP67 and NEMA 6 standards for harsh environments Available in opposed, polarized and non-polarized retroreflective, convergent, regular and wide-angle



Waterproof and dustproof, reliable and safe

The outer classic sink design allows the sealing ring of the cabinet and door to be seamlessly compressed without leaving a trace of gaps



Metal-coated optical fiber sensors for adaptive structures

Adaptive systems modify their configuration in response to the environment, an idea informed by biomimicry. This study reports early-stage development of metal-coated fiber Bragg grating (FBG)



FU-95S Fiber Optic Sensor

Product description Sensor FU-95S Fiber Optic
Sensor Report an issue with this product or seller

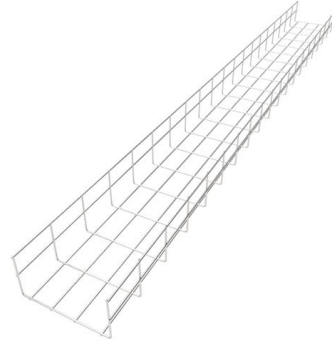

Fiber Optic Shape Sensors: A comprehensive review

Fiber optic shape sensing has recently captured the attention of academia and industry and has been investigated by research groups worldwide. This outstanding technology enables the

Single-Channel Single-Fiber 3D Shape Sensing Based

Here, a single-channel single-fiber shape sensing scheme is proposed based on cascaded cladding fiber Bragg gratings (cl-FBGs) fabricated

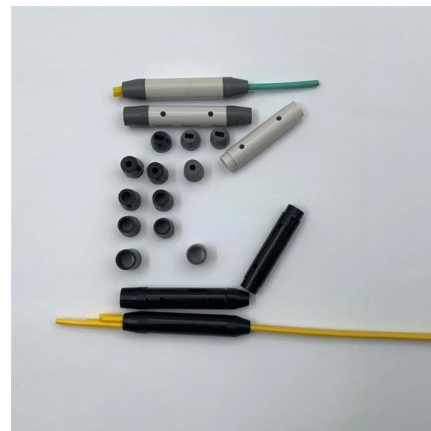

3D-printed multi-material optical fiber sensor for dual sensing

Optical fiber sensors are widely utilized for their precision, stability, adjustable functionality, and minimal signal degradation. They excel in detecting diverse parameters, even in challenging



Industrial Fiber Optics

Industrial Fiber Optics is a world leader in manufacturing polymer and large-core silica optical fiber cable assemblies. We specialize in providing leading edge



Fiber optic shape sensing

Fiber optic shape sensing has an outstanding capability to sense curvature and shape in 2D and 3D.



Photoelectric Sensors , Fiber-Optic Sensors , Fiber

Batch setting of Fiber-Optic Sensors Settings can be made collectively for linked (expanded) Fiber-Optic Sensors. Zero reset and various types of teaching, as



FS2-60 Fiber Optic Sensor

Fibre optic amplifiers can be used as a type of sensor that is either beam or diffuse. The sensing combination of fibre optic amplifiers and fibre optics can cope with the sensing needs in



- IP65/IP55 OUTDOOR CABINET
- OUTDOOR CABINET WITH AIR CONDITIONER
- OUTDOOR ENERGY STORAGE CABINET
- 19 INCH



Next Day Automation Used IFM E20603 Fiber Optic Through Beam Sensor

From our inventory we are selling a IFM E20603
Fiber Optic Through Beam Sensor M3 Head, 1mm
Core, 20mm Head. Specifications:, Model # :
E20603, FE-11-EPA-M3/F1X1/2M, More
Information :,



E3X-ZV11 Fiber optic switch sensor

E3X-ZV11 Fiber optic switch sensor : Amazon.ae:
Industrial & Scientific High Precision:Reliable
ensures accurate measurements in challenging
conditions High Temperature
Resistance:Withstands up,



Contact Us

For datasheets, pricing, or custom high-speed optical interconnect solutions,
please visit:
<https://www.syropy.com.pl>